



GOVERNMENT OF WEST BENGAL  
DIRECTORATE OF FORESTS  
OFFICE OF THE DIVISIONAL FOREST OFFICER,  
RUPNARAYAN DIVISION.  
Rangamati, Midnapore. PO-Vidyasagar University,  
Dist – Paschim Medinipur, Pin-721102.  
E-mail ID :: dforupnarayan@rediffmail.com.



\*\*\*\*\*  
**E-TENDER NOTICE NO. WBFOR/DFORUP/ENIT\_50/SFDA ( 2<sup>nd</sup> Call ) OF 2018 -19**  
**OF THE DIVISIONAL FOREST OFFICER, RUPNARAYAN DIVISION,**  
**WORKS FOR CONSTRUCTION OF DRYING PLATFORM & SEMI PROCESSING UNIT.**  
\*\*\*\*\*

Drying Platform & Semi processing units are required at Central Nurseries, that is to be taken up at different Ranges under the jurisdiction of this Division. Thus, in pursuance to the G.O No-5400-F(Y) ; Dt. 25/6/12 and its subsequent amendment No-2254-F dt 24/4/14, the Divisional Forest Officer Rupnarayan Division, Rangamati, Midnapore on behalf of Governor of West Bengal invites **E-TENDER** from bonafide, resourceful Contractors for carrying out the following works at various Range(s) of Rupnarayan Division as per following location details & estimates in the table below.

**LOCATION DETAIL & FEES ETC.**

NIT No	Item of Works	Location	Unit (No)	Estim. Amount with GST, CESS etc. (Rs)	EMD (2% approx)	SECURITY Deposit	Completion Time
50	Const. of Drying Platform.	Amlagora Range, Pathrisole Beat.	1	8,75,800.00			Within 21(twenty one) days from the date of issue of Work Order.
	Construction of Semi processing Unit.		1	3,29,500.00			
<b>Total</b>				<b>12,05,300.00</b>	<b>24110.00</b>	10% of Offered Rate	

**DETAILS OF ESTIMATE ENCLOSED BELOW.**

### ANALYSIS OF THE ESTIMATES

1. The estimates are based on current PWD schedule of rates. Intending bidders are required to analyze the plan and estimates very carefully to avoid any future controversy.
2. The mode of deduction of GST, Labour Welfare Cess shall be decided by the undersigned as per existing rules. The contractor/s do not have any claim over contingency. It shall be the discretionary power of undersigned to utilise the amount as per exigency and to meet up the expenditure related to advertisement, estimate preparation cost, necessary modification in plan any estimates, if any, Intending bidders should quote their rate accordingly.
3. Whenever labourers are engaged, the same should be as per direction of the concerned Range Officer or his authorized person. Priority should be given to the members of JFMCs concerned in this regard. Minimum Wage, as per latest Minimum Wage Act shall have to be paid to the labourer so engaged.
4. The estimate is indicative in nature. Thus, it might be so that some of the items mentioned in the estimates do not require to be implemented in the field and some of the items needs to implemented more than once, repeated or enhanced as per field requirements.
5. Rate quoted below 20% shall be subject to rate analysis. Such rate analysis shall required to be submitted through e-mail within 24 Hrs of the opening of financial bid (**e-Mail - [dforupnarayan@rediffmail.com](mailto:dforupnarayan@rediffmail.com)**), failing which it will be presumed that the bidder are unable to justify the rate technically and such financial bid/s shall not be accepted from this end and 2<sup>nd</sup> lowest bidder who had quoted rate not below 20% shall be considered. One can also submit the hard copy of the rate analysis in sealed cover by name of the tender inviting authority.
6. Payment shall be made to the successful bidders only for those items which he/she has carried out at field as per the instructions of the concerned Range Officers or his authorized persons or his superior authority. Each item of the estimates has a definite time line, beyond which the item can't be implemented in the field. Thus any item which is not possible to be implemented in the field within due time, can only be implemented after having due permission in this regard from the appropriate authority. Successful bidders are required to prepare bill for making payment accordingly.
7. Intending bidders are required to mention the cluster/s (**Annexure-1**) if applicable, in which he/she is willing to participate. Rate in BOQ is required to be quoted accordingly. If the no of clusters are not mentioned, the tender may liable to be cancelled.
8. From the above analysis, it follows logically that R.A bills shall be admissible in this regard.

### SCHEDULE OF DATES

TYPE	DATE
Date of uploading of N.I.T & Other document (Online Publishing Date)	<b>27//02/2019 11.00 AM</b>
Document Download Start date.	<b>27//02/2019 11.00 AM</b>
Bid submission <b>Start date</b> Online	<b>27//02/2019 11.00 AM</b>
Last date for submission of uploaded copies of Tender documents & EMD ( <b>Offline</b> )	<b>15/03/2019 up to 5.00 PM</b>
Bid submission <b>Closing date</b> (Online)	<b>14/03/2019 up to 4.00 PM</b>
Bid Opening date for <b>Technical Bid</b> (Online)	<b>16/03/2019</b>
Date of uploading of list of Technically qualified bidders ( <b>Online</b> )	<b>16/03/2019</b>
Date of uploading of final list of technically qualified bidders after disposal of appeal (Online)	<b>To be Notified in due course</b>
Date of Opening of <b>Financial Bids</b> (Online)	<b>To be Notified in due course</b>

Website from where the tender can be seen	<b>1) Website of Directorate of Forest , Government of West Bengal. 2) District Portal, Paschim Medinipur. 3) e- procurement portal, Government of West Bengal.</b>
Relevant Website for Viewing & Participating in e-Tender.	<a href="http://www.wbtenders.gov.in">www.wbtenders.gov.in</a>
Tender Fee.	<b>Rs. 1,000.00 will be applicable for accepted L1 Bidder only as DD drawn in favour of Divisional Forest Officer, Rupnarayan Division, payable at Midnapore.</b>

### GENERAL TERMS AND CONDITIONS

1. **In some case, the location may also vary/changed depending on the field situation. Payment shall be made on pro rata basis based on the rate offered by the successful bidder, in that case.**
2. **Pattern of Tender- Invitation of tenders are indicative in nature. It is being floated in anticipation of administrative approval and subsequent financial sanction. In case of non availability of such approval the tender shall be cancelled outright without assigning any further causes. Cost of the tender papers, if any, is non refundable in nature. No prayer, in case of such cancellation, shall be entertained under any circumstances. In case of the requisite approval from appropriate authorities also, work order to the successful bidders shall only be issued when fund will be placed and which shall be free from any other encumbrances.**
3. **Procurement of tender paper-** The tender paper shall have to be procured from e procurement portal, Govt of West Bengal. The intending bidders may also visit the official website of Forest Directorate for information.
4. **Tender should be submitted in favour of **Divisional Forest Officer, Rupnarayan Division** and not by official designation only. The tender shall be made in two bid system viz- Technical bid and Financial bid. Following folders are required to be uploaded with a single folder superscripting technical bid.**
  - a. Company information folder- related all information including audit report etc.
  - b. Financial Credential folder - All experiences related to similar nature of job includes – construction of buildings, building related construction works, store houses, ware houses & such other similar nature of works. Only work completion reports with an abstract mentioned in the annexure-II.
  - c. Folder related to company hierarchy and technical person.
  - d. The technical bids must not contain any pricing information under any circumstances. In such case the tender shall be liable to be cancelled.
5. **Submission of Tender- In general, the tenders are allowed to participate in all tenders/clusters; subject to evaluation of financial credentials submitted for the purpose. The technical bids thus submitted by the intending bidders shall be scrutinized by the tender committee constituted for the purpose, based on 2 grounds – a) The experience of the intending bidders & b) The financial credential submitted for the purpose.**
6. **Technical Bid-** Technical Bid should be submitted in separate folder other than financial bid. Clearly super scribing the tender notice no and specific cluster in which the intending bidders are willing to participate. Work of similar nature implemented in a particular financial year (not more than three years old) shall only be considered to be eligible for technical bid. Other documents such as GST/VAT, PAN, TAX, License/Registration as applicable, additional information if any, shall also be submitted in the folder. The other credential like company details, machinery, technical persons, other technical knowhow, as applicable, shall be required to be submitted. The Technical bid must not contain any pricing information. The Address and Contact No. of the bidder should be clearly written on the envelope.
7. **Financial Bid-** Financial Bid will not be opened unless the information and documents provided in the Technical Bid are as per the eligibility criteria and as per satisfaction of the undersigned.
  - i) The financial bid should also be submitted in a separate cover super-scribed as **Financial Bid & "Tender Notice No. and cluster no."**. The bid should mention in both number & words, & should be written in bold letters.

- ii) Address and contact No. of the Bidder should clearly written on the cover.
  - iii) Financial Bid format is given in Form IIA.
  - iv) The Bank details of the tenderers must be mentioned in the Form IIA for making payments on line. This is obligatory.
  - v) Financial bid must be inclusive of all taxes.
  - vi) Amount quoted more than the estimated cost will not be accepted in general, subject to the discretionary power of the undersigned based on the recommendation of the tender committee constituted for the purpose.
8. **Eligibility Criteria-** It consists of two parts – (A) Experience of implementing similar nature of job, (B) The requisite assessment of financial potential of the bidders & (C) Duration of completion of the job of similar nature.
- i. The requisite assessment of financial potential of the bidders-The intending bidders must be having **at least 80% of the estimated cost as financial credentials for a single contract or 50% for 2 contracts or 40% for 3 contracts, to be calculated for particular financial year which one is maximum (Not more than 3 years' old)**. Requisite documents such as PAN, VAT, GST, IT Returns for last 3 financial years, other relevant License etc. as applicable as per existing rules, must be submitted in the technical bids.
  - ii. The duration of implementation of job is also very important. Intending bidders, who took longer time than the time schedule mentioned in the work order in case of similar nature of jobs, might not be considered at all, subject to the discretionary power of the undersigned.
- After assessment of the eligibility criteria a weightage will be provided against each technical bid in 1 to 10 points scale. Those who will score at least 7 points shall only be eligible to qualify the financial bid.
9. **Time to Complete the works-** Delay in completion of each item of works as mentioned in the estimate and as directed by the concerned Range Officer or his authorized person or any superior officer in the rank above Range officer, might attract the penalty to the contractors subject to the discretionary authority of the undersigned depending on the field situation and other requisite factors required to be considered in this regard.
10. **Submission of EMD and Security-** EMDs are required to be submitted as per guidelines mentioned in the G.O No-3975-F(Y) dt 29/07/16 and subsequent G.O No-2365-F(Y) dt 12/04/18 through ICICI Bank payment gateway either by using internet banking or by NEFT/RTGS. The procedure is mentioned below -

- a. Payment by NET BANKING ( Any linked bank) through ICICI Bank payment Gateway.
  - ✓ On selection of net banking as payment mode, the bidder will be directed to ICICI Bank payment gateway web page 9(along with a string containing unique ID) where he will select the bank through which he wants to do the transaction.
  - ✓ Bidders will make the payment after entering his unique ID and password of the bank to process the transaction.
  - ✓ Bidder will receive a confirmation message regarding success/failure of the transaction.
  - ✓ If the transaction is successful, the amount paid by the bidder will be credited in the respective pooling account of State Government/PSU/Autonomous body/Local body/PRI's etc maintained with the Focal Point Branch of ICICI at R.N Mukherjee Road, Kolkata for collection of EMD/Tender Fee.
  - ✓ If transaction is a failure, then bidder will go back to step one and try again.
- b. Payment through NEFT/RTGS
  - ✓ On selection of RTGS/NEFT as payment mode, the e- procurement Portal will show a pre-Filled challan having the details to process RTGS/NEFT transaction.
  - ✓ The bidder will print the challan and use pre filled information to make RTGS/NEFT payment using his bank account.
  - ✓ Once the payment is made, the bidder will come back to e- Procurement portal after expiry of reasonable time to enable the NEFT/RTGS process to complete, in order to verify the payment made and continue the bidding process.
  - ✓ If verification is successful, the fund will get credited to the respective pooling account of State Government/PSU/Autonomous body/Local body/PRI's etc maintained with the Focal Point Branch of ICICI at R.N Mukherjee Road, Kolkata for collection of EMD/Tender Fee.
  - ✓ In case of unsuccessful process the amount will be refunded to bidder's account.

Security Deposit shall be given by Accepted L1 Only. The Security shall require to be given in TR-7/GRIPS Challan as the case may be. Security may also be adjusted through **RA Bills** also; subject to the discretionary power of the undersigned and rules/G.Os regarding the matter in vogue. Security may also be adjusted with **EMD** and **RA bills** also, subject to subject to the discretionary power of the undersigned and rules/G.Os regarding the matter in vogue. The Head of account for depositing the EMD with Operator's Code is **8443-00-109-003-07** ( EMD) ( Operator's Code-**109**) and that of Security deposit with Operator's Code is **8443-00-109-003-07** ( Security Deposit) ( Operator's Code-**109**). The adjustment through refund shall be made through the head of Account **00-8443-00-109-003-0-23-00** after maintaining due formalities in this regard.

- 11. Special additional Security-As per GO No- 4608-F(Y) dt 18/7/18 , a special additional security is required to be submitted by the successful bidder to the tune of 10% of the estimates tender amount in the form of a bank guarantee in case of accepted bid is 80% or less of the estimated tendered amount. The same will be released on successful implementation of the work at the time of release of security.**
- 12. Dispute Resolution** - In case of any dispute, the decision of the Divisional Forest Officer, Rupnarayan Division shall be final and on appeal which should be made within 30 days from the date of awarding decision to the incumbent, the decision of the chief Conservator of Forests, Western Circle, West Bengal, shall be final and binding.

### **OTHER TERMS AND CONDITIONS**

- 1. An Affidavit of 1st Class Magistrate/Notary, duly signed by the intending bidders, declaring the following points shall be required to be submitted by the intending bidders along with the technical bid. If the affidavit is not submitted along with the technical bids, the tender submitted by the intending bidders shall be liable to be cancelled. However it shall be mandatory for the successful bidders to submit an affidavit of 1<sup>st</sup> class magistrate before signing of agreement and within 7 days from the date of issuance of offer/direction letter of submission of security deposit**
  - a. I have read and understood the meaning of the clauses mentioned in the tender notice no- in letter and spirit**
  - b. The documents submitted and information provided by me are true to the best of my knowledge and beliefs.**
  - c. I shall abide by all the terms and conditions mentioned in the tender notice and such other terms and conditions issued by the tender inviting authority/ other appropriate authority time to time for smooth implementation of the works.**
  - d. I case of any dispute, I vouch that, the decision taken by Divisional Forest Officer, Rupnarayan Division shall be final and on appeal, the decision taken by the Chief Conservator of Forests, Western Circle, shall be final & binding upon me.**
2. Validity of the tender will be 1 ( One ) Year from the date of issue of work order, which can be extended for another 6 (Six) months, or up to the end of next financial year, as may be decided by the appropriate authority.
3. The undersigned reserves the right to place order for work for supply up to 20% more or 20% less of the quantity mentioned in the schedule of the tender.
4. The undersigned reserves the right to cancel the tender, if necessary, without assigning any reason whatsoever.
5. The undersigned is not bound to accept the lowest rate quoted by the tenderer and he is not bound to assign any reason, whatsoever, for such non-acceptance.
6. The undersigned reserves the right to accept the tender only after verifying / testing the sample up to the satisfaction.
7. The undersigned or his representatives will inspect the works, take necessary measurement, and perform the required tests as and when required. The tenderers should render the required co-operation in this regard.
8. It shall be the discretionary power of the undersigned for accepting any prayer for part payment or not. In general no part payment prayer shall be entertained.
9. During the inspection by the undersigned or his representative, if the quality of the work / supply is not found up to the standard, the contractor/ supplier is bound to rectify the work or supply up to the satisfaction of the undersigned or his representative. Otherwise, the work order will be cancelled and the security deposit will be forfeited to the Govt. of West Bengal.
10. The work order will be issued to the successful contractor only after placement of fund by the Government.

11. No extension of time will be allowed for delivery / execution of the work. The Tenderer / contractor shall not be considered in default, if delay in delivery / execution occurs due to causes beyond his / her control, such as acts of God, natural calamities, civil wars, fire, strike, frost, floods, riot and acts of unsurpassed power. In the event of delay due to such causes, the tenderer may apply to the Divisional Forest Officer, Rupnarayan Division for extension of time for that period. The Division Forest Officer, Rupnarayan Division at his own discretion may extend for a length of time equal to the period of force majeure or such period as he think suitable for that or may be cancelled. Such cancellation would be without any liability whatsoever on the part of the undersigned.
12. Materials will have to be procured by the tenderers by themselves following the standard and specification of PWD/PHE Schedules of the district, or as per the specification as decided by the Range Officer concerned or his higher officer, subject to the approval of the undersigned or his Sub-ordinate officers. In case of any material supplied by the department, the cost of such material will be recovered from the contractor.
13. The tenderers are required to inspect the sites, site plans and specifications of the works before submission of the tender and future ignorance of any such item will not be entertained.
14. All works are required to be carried out as per plan and specification & estimate of the project subject to the modification by the undersigned at any point of time during execution of the work duly notified to the contractor/supplier, within the project cost.
15. Royalty for any material, if obtained from Forest area, will have to paid by the contractor. Even if the material is procured from other Govt. Deptt's resources, the receipt for payment of such material must be shown and photo copies to be attached with the bill. Extra payment for such payment of Royalty etc. will not be entertained by the undersigned.
16. All tools & plants required for execution of the works should be procured by the contractor at his own cost. The standard of such tools & plants will be as per the specification of the P.W. Dept/ P.H.E.
17. Statutory Deduction : Income Tax, VAT, Labour Welfare Cess as applicable shall be deducted from the Gross amount of Bill.
18. In addition to above, before payment the following documents are required to be produced, if applicable.
  - a) Xerox copy of Labour license as per provision of "West Bengal Contract Labour (R&A) Act 1970" for execution of the scheme (original to be shown for verification).
  - b) Xerox copy of DCR ( with RA Bill/Final Bill –in original to be shown for verification ) as a documentary evidence for payment of Royalty &CESS in Minor minerals or original Challan(s) carrying order (s) mentioning the name of Agency, Tender Notice No. & date received from Govt. Approved Lessee/ Permit holder.
19. The successful tenderer will not assign any part of the work to any other contractor.
20. The successful tenderer may, however authorize any person to supervise the day to day work, attend the measurement when taken by the undersigned or by his authorized Officer and record his signature on the work measurement note books.
21. Rate offered in the estimate is the final and tenderer will not have any further claim.
22. The acceptance of the tender will be subject to the receipt of the approval of the higher authorities and availability of fund. The undersigned will not be responsible for any loss sustained by the tenderer in the event of non receipt of Government sanction.
23. The payment of bill for any work will be made according to the availability of fund and approval of higher authorities wherever applicable and no claim to delay in payment will be entertained.
24. The terms and conditions of this "Tender Notice inviting tender" is part and parcel of the contract form.
25. In case of any dispute in execution of the work or supply, an application may be made to the Divisional Forest Officer, Rupnarayan Division and the decision of the undersigned is final and binding.
26. The cost Tender paper / Form will be sold as per Govt. of WBs notification no. 452-A/PW/O/10C-35/10, Dt-26/07/2011.
27. Requisite license must be obtained for Labour Department after issuance of work order. No payment shall be made without production of the license.
28. **Forest Department, Rupnarayan Division or any staff of the Division, shall in no way be held responsible under any circumstances for any accident or death of the labourer / driver etc. engaged by the contractor, happened in the field during the time of implementation of the works.**
29. **Range officer or his authorized person/s shall have the discretionary power to deploy suitable labourers, preferably from among the FPCs concerned.**

30. **In case of implementation of the works at field the decision of the Range Officer or his authorized persons or any of his superior officers shall be final and binding on the successful bidders implementing the works at field.**
31. **Payment shall only be made to the successful contractor(s) after the Range Officer concerned, certifies so ensuring the quality of the work and implementation of the works as per estimates and plan subject to overriding power of the undersigned in this regard.**
32. **The mode of payment for successful completion of the works should be made by NEFT/RTGS/Cheque issued by the concerned authority, in case of successful implementation of the works to the successful contractors.**
33. **Please follow annexure carefully during submission of tender.**

SD/-

**ARNAB SENGUPTA, WBFS**  
DIVISIONAL FOREST OFFICER  
**RUPNARAYAN DIVISION**  
RANGAMATI, MIDNAPORE.

**ANNEXURE – I  
PRAYER FOR PARTICIPATION IN THE TENDER**

Name of Tenderer ::

Address ::

Tender Notice No. ::

Cluster No. ::

Financial Credential for similar nature of job ( as mentioned in the tender notice)

Bank details (A/c No., IFS Code & MICR code (optional))

Declaration : I / we do hereby declared the statement made by me is true the best of my knowledge in belief. If allow I/We shall abide by all the terms and conditions mentioned in the tender notice and the direction of the authority. I /We read the tender document carefully and understood it in letter inspirit.

Signature of Bidder with date .....



**TECHNICAL BID FORMAT**

Form IA-General Information about the Organization

SI No	Particulars	Details to be furnished
-------	-------------	-------------------------

Details of the Bidder (Organization )

1	Name	
2	Address	
3	Telephone/Mobile No.	
4	Email	
5	Fax	
6	Website	

Details of Authorized Person

7	Name	
8	Address	
9	Telephone/Mobile No.	
10	Email	

Information about the Organization

11	Status of Organization (Proprietorship/Partnership/Public Ltd/Pvt. Ltd/ Co-operative Society etc.)	
12	Details of Registration of Organization	Date: Ref:
13	Number of Professionals in position in the organization	
14	Locations and address of offices	
15	Service Tax Registration Number	
16	VAT Registration Number(Enclosed latest VAT Return)	
17	Professional Tax Registration Number	
18	Income Tax PAN Number	
19	Details of any other Licenses/Registration (Copy to be enclosed)	

Signature of the Tenderer with date

**(Annexure-II)**

Form I-B "Summary of Similar Projects Implemented " ( Year wise)

Sl No	Name of the Customer	Project Name	Brief narration of the type of work implemented	Start Date	End Date	Contact Value (only net checked amount issued by authority	Financial year of the completion of the work	Supporting documents against the completion report ( Yes/No)	Whether Successfully completed	Address &Phone no. of the work completion issuing authority.

Signature of the Tenderer with date

(Annexure-III)

**FINANCIAL BID FORMAT**

**(FINANCIAL BID NOT TO BE DISCLOSED ONLY THE TAXES ARE TO BE MENTIONED)**

Form II-A

Tender Notice No	Item of Works	Estimated Cost exclusive of GST and CESS	Offered Rate				Name of Contractor & Address
			Offered rate	Applicable GST	Other Statutory deduction	Applicable Labour less	
			NOT TO BE DISCLOSED DURING UPLOADING OF TECHNICAL BID				

Declaring that the item against which there are fixed Govt. rate such as minimum wage rate etc. shall be obeyed in letter in spirit

Signature of the Tenderer with date

No. 331 / 2 – E Tender

Dated, Midnapore the 25 / 02 / 2019

Copy forwarded for wide circulation & information to:-

1. The **Sabhadhipati**, Paschim Medinipur Zilla Parishad.
2. The **Principal Chief Conservator of Forests (HoFF)**, West Bengal
3. The **Chief Conservator of Forests**, Western Circle, West Bengal.
4. The **District Magistrate**, Paschim Medinipur.
5. The **Superintendent of Police**, Paschim Medinipur.
6. The **D.I.C.O.** , Paschim Medinipur.
7. The **Sub-Divisional Officer**, Midnapore Sadar, Paschim Medinipur.
8. The **Treasury Officer**, Midnapore Treasury.
9. All Divisional Forest Officer's, Western Circle, West Bengal.
10. The Assist. Divisional Forest Officer, Rupnarayan Division.
11. The Head Clerk, Rupnarayan Division.
12. The Budget, Accounts & Revenue Section.
13. All Range Officers (Territorial), Rupnarayan Division.
14. The A.F.R, Rupnarayan Division.
15. Notice Board, Rupnarayan Division.
16. Shri / FPC\_\_\_\_\_.

SD/-

**ARNAB SENGUPTA, WBFS**  
DIVISIONAL FOREST OFFICER  
**RUPNARAYAN DIVISION**  
RANGAMATI, MIDNAPORE.

**PROPOSED ESTIMATE FOR CONSTRUCTION OF DRYING PLATFORM (1291.20 SQFT.)**

**[ The Rate Based On P.W.D. Schedule Effect from 1st November , 2017 ]**

Sl. No	Description of item	M.F.	No.	L (m.)	B (m.)	D (m.)	Quantity	Unit	Rate (Rs.)	Amount (Rs.)
1	{ P.W.D. / Page No. 1 / Item No. 2(a)} Earth work in excavation of foundation trenches or drains, in all sorts of soil etc. (a) Depth of excavation not exceeding 1,500 mm. For Post Grouting For Guard Wall "		2X6	0.850	0.850	0.750	6.503	cum.	119.27	1116.90
							1.944			
							0.918			
							9.365			
2	{ P.W.D./Page No. 2/ Item No. 4(B)} Filling in foundation or plinth by fine sand.		1	14.500	6.000	0.075	6.525	cum.	509.85	3326.77
							6.525			
3	{ P.W.D. / Page No. 47 / Item No. 3 } Supplying and laying Polythene Sheet (150gm / sq.m.) over damp proof course or below flooring or roof terracing or in foundation or in foundation trenches.		2X6	0.850	0.850		8.670	sqm.	24.00	2601.36
							8.640			
							4.080			
							87.000			
							108.390			
4	{ P.W.D./Page No. 34 / Item No. 22(A)(a)} Cement Concrete with graded stone ballast 40 mm size(Excluding shuttering )etc. (A)Pakur variety (a) 1:3:6 proportion		2X6	0.850	0.850	0.100	0.867	cu.m.	5207.00	9481.95
							0.648			
							0.306			
							1.821			

Sl. No	Description of item	M.F.	No.	L (m.)	B (m.)	D (m.)	Quantity	Unit	Rate (Rs.)	Amount (Rs.)
5	{ P. W. D./ Page No. 24 / Item No. 4(i)} Ordinary Cement concrete (mix 1:2:4) with graded stone chips (20 mm nominal size) excluding shuttering and reinforcement,if any, in ground floor as per relevant IS codes. i) Pakur Variety For Post Grouting Floor		2X6 1	0.450 15.000	0.450 6.500	0.700 0.100	1.701	cum.	5396.74	61798.07
							9.750			
							11.451	cum.		
6	{ P.W.D./Page No. 42/ Item No. 36 (f)} Hire and labour charges for shuttering with centreing etc. (f) 25 mm to 30 mm shuttering without staging in foundation		2 2	15.000 6.500		0.100 0.100	3.000	sqm.	203.00	872.90
							1.300			
							4.300	sqm.		
7	{ P.W.D./Page No. 15 / Item No. 8(a)} Brick work with 1st class bricks in cement mortar (1: 6) (a) In foundation and plinth For Guard Wall		2 2	10.800 5.100	0.250 0.250	0.200 0.200	1.080	cum.	5140.00	8172.60
							0.510			
							1.590	cum.		
8	{ P.W.D./Page No. 16 / Item No. 16} 125 mm. thick brick work with 1st class bricks in cement mortar (4:1) in ground floor.		12X2 12X2	0.700 0.450		0.700 0.700	11.760	sqm	705.00	13620.60
							7.560			
							19.320	sqm.		
9	{ P.W.D./Page No. 189 / Item No. 189} 15 mm thick cement sand plaster to wall(6:1) etc.		2 2	15.000 6.500		0.150 0.150	4.500	sqm.	136.00	877.20
							1.950			
							6.450	sqm.		

Sl. No	Description of item	M.F.	No.	L (m.)	B (m.)	D (m.)	Quantity	Unit	Rate (Rs.)	Amount (Rs.)
10	{ P.W.D./Page No. 48 / Item No. 6(ii)}  Artificial stone in floor, dado, staircase etc with cement concrete (1:2:4) with stone chips, laid in panels as directed with topping made with ordinary or white cement (as necessary) and marble dust in proportion (1:2) including smooth finishing and rounding off corners including raking out joints or roughening of concrete surface  (ii) 25 mm. thick		1	15.000	6.500		97.500	sqm.		
							97.500	sqm.	269.00	26227.50
11	{P.W.D./Page No.192 / Item No. 15 }  Neat cement punning about 1.5mm thick in wall, dado, window sill, floor etc.		2	15.000		0.150	4.500			
			2	6.500		0.150	1.950			
							6.450	sqm.	34.00	219.30
12	{P.W.D./Page No.100 / Item No. 2(i) }  M.S. structural works in roof trusses with tubular sections conforming to IS: 806-1968 & IS: 1161- 1998 connected to one another with bracket, gusset cleats as per design, direction of Engineer-in-charge complete including cutting to requisite size, fabrication with necessary metal arc welding conforming to IS: 816-1969 & IS: 9595 i) For trusses spanning up to 12.00 m 65 MM Dia M.S. Pipe  40 MM Dia M.S. Pipe  25 MM Dia M.S. Pipe									
				2X6X3.600=43.200 M						
				43.200 M X@ 6.53 kg/m=						
				282.096 kg						
				6X1X6.500=39.000 M						
				6X2X3.500=42.000 M						
				6X1X0.900= 5.400 M						
				2X4X15.000 = 120.000M						
				206.400 M X@ 3.61 kg/m=						
				745.104 kg						
				6X2X1.000= 12.000M						

Sl. No	Description of item	M.F.	No.	L (m.)	B (m.)	D (m.)	Quantity	Unit	Rate (Rs.)	Amount (Rs.)
				6X2X0.750 =9.000 M 6X2X0.450= 5.400 M 6X2X0.300= 3.600 M						
				30.000 M X@ 2.46 kg/m= 73.800 kg						
	6 mm thick plate			12X0.300X0.300= 1.080 Sqm 12X2X0.200X0.200= 0.960 Sqm 2.040 sqm X@ 47.100 kg/sqm= 96.084 kg			1.197	M.T.	72951.00	87322.35
13	{P.W.D./Page No.81 / Item No. 10} Galvanised iron sheet ridging fitted with necessary bolts, screws, washers etc complete.(225mm end lapping) (B) 450 mm lapping each way (b) In wall: with 0.63 mm. sheets.		1	15.000			15.000	sqm.		
							15.000	sqm.	490.00	7350.00
14	{P.W.D./Page No.81 / Item No. 9} Galvanised corrugated iron sheet work (excluding the supporting frame work) fitted and fixed with 10 mm. dia J or L hook-bolts, limpet and bitumen washers and putty complete with 150 mm. end lap and one corrugation minimum side lap. (Payment to be made on area of finished work)(  (i) In Roof:- b) With 0.63 mm thick sheet		2	15.000		3.250	97.500	sqm.		
							97.500	sqm.	644.00	62790.00
15	{P.W.D./Page No. 200 / Item No. Priming one coat on Steel or other metal surface with synthetic oil bound primer of approved quality including smoothening surfaces by sand papering etc..									
	65 MM dia pipe	1.00	1	43.200		0.350	15.120			
	40 MM dia pipe	1.00	1	206.400		0.160	33.024			
	25 MM dia pipe	1.00	1	30.000		0.100	3.000			
							51.144	sqm.	29.00	1483.18



Sl. No	Description of item	M.F.	No.	L (m.)	B (m.)	D (m.)	Quantity	Unit	Rate (Rs.)	Amount (Rs.)
16	{P.W.D./Page No. 200 / Item No. 2(A)(iv)} Painting with best quality synthetic enamel paint of approved make and brand etc. (b) On Steel or other metal Surface. (iv) Two Coats (With any shade except white) Quantity same as Steel Primer						51.144	sqm.	79.00	4040.38
<b>TOTAL (Rs.)</b>										<b>291301.05</b>
<b>Add @ 12% for G.S.T (Rs.)</b>										<b>34956.13</b>
<b>TOTAL (Rs.)</b>										<b>326257.18</b>
<b>Add @ 1% for Cess (Rs.)</b>										<b>3262.57</b>
<b>GRAND TOTAL (Rs.)</b>										<b>329519.75</b>
<b>SAY (Rs.)</b>										<b>329500.00</b>
<b>(Rupees Three Lakh Twenty Nine Thousand Five Hundred Only )</b>										

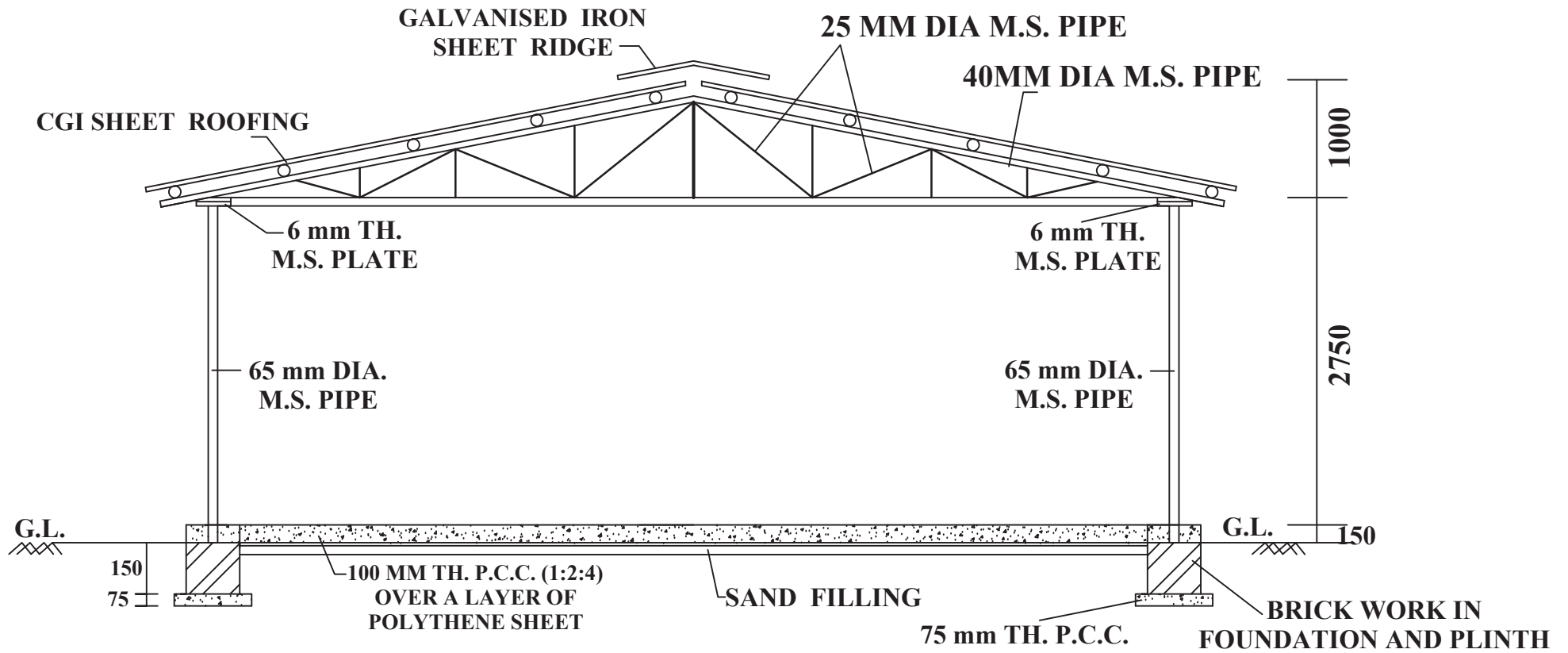

## SECTIONAL ELEVATION

8000MM

15000 MM

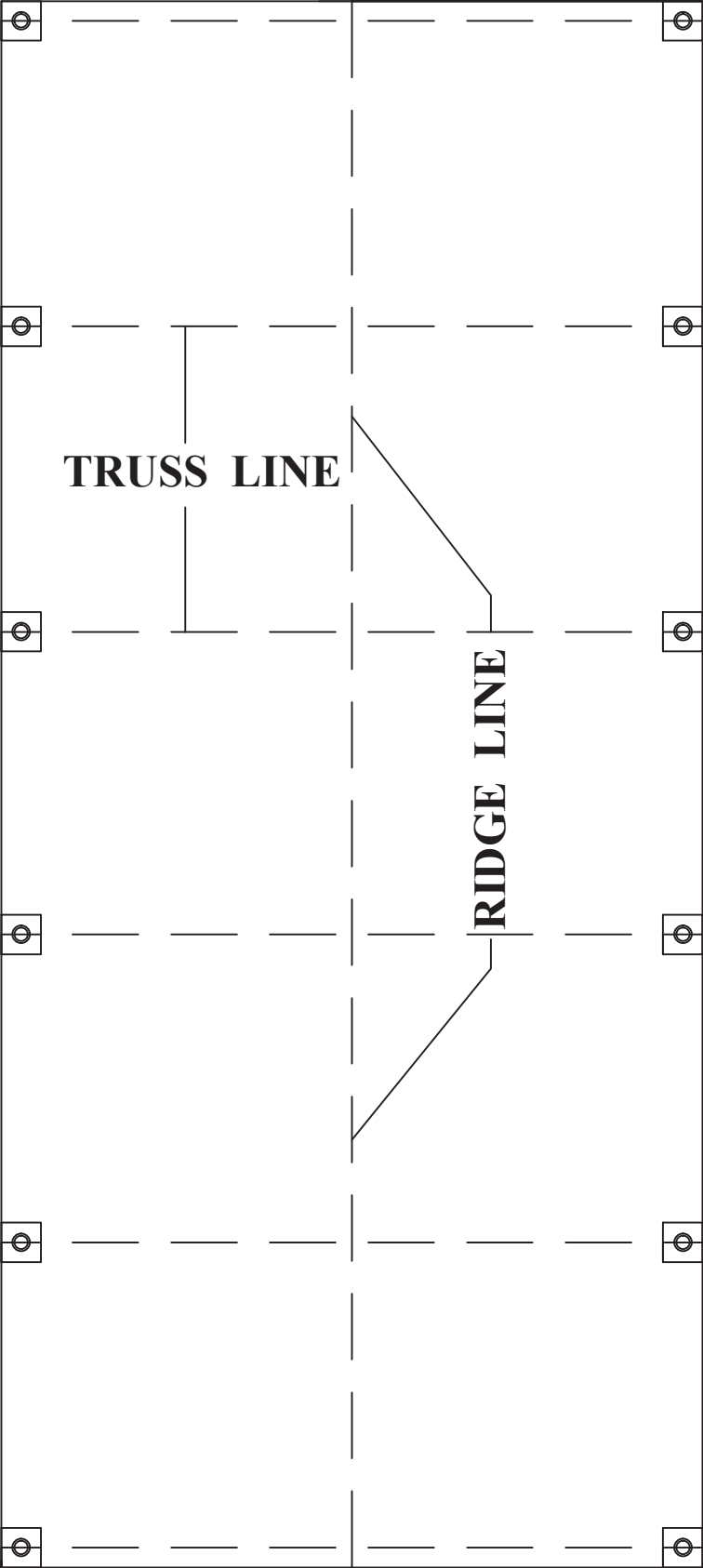

TRUSS LINE

RIDGE LINE

PLAN

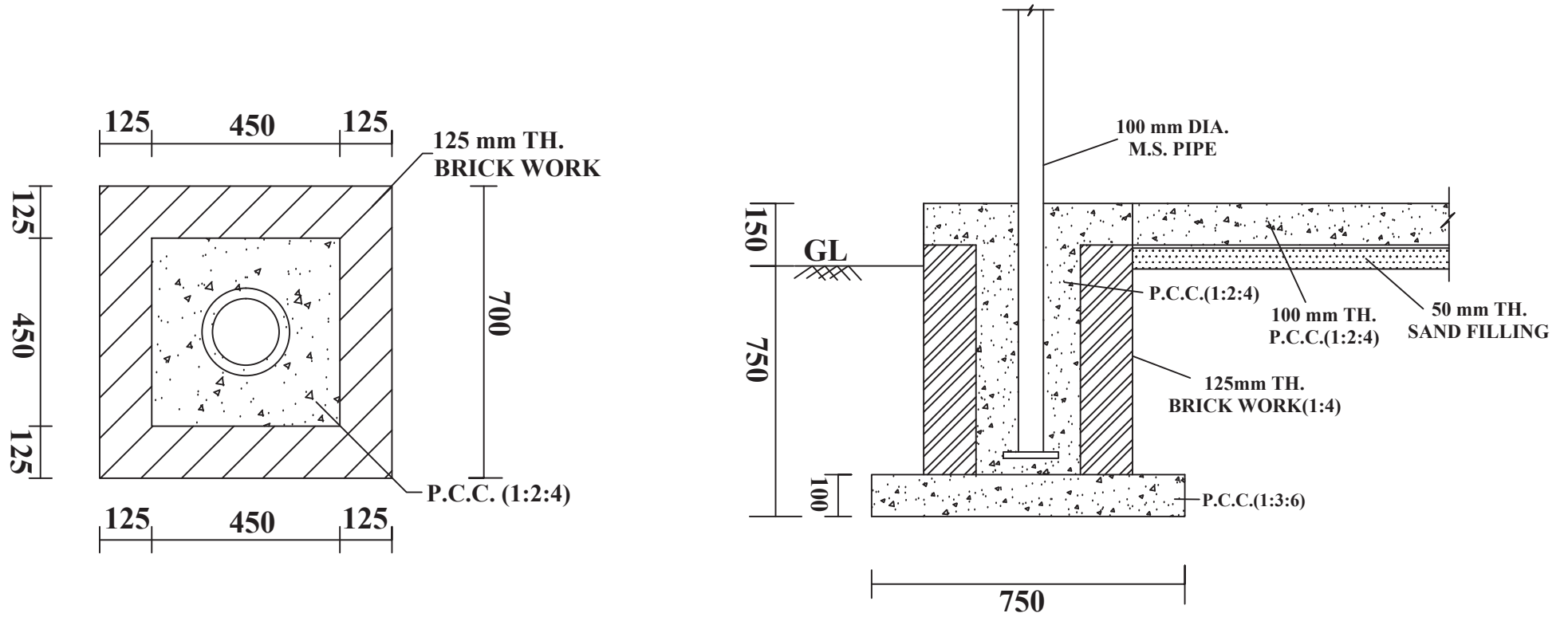

**DETAILS OF POST GROUTING**

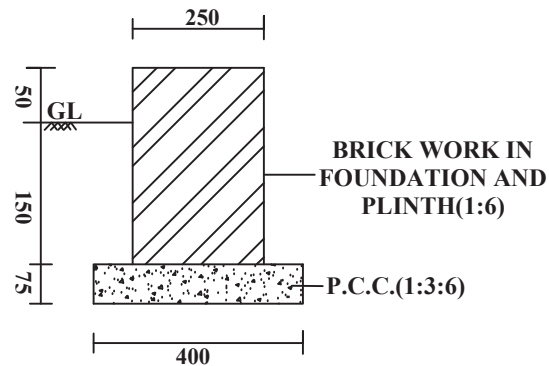

**CROSS SECTION OF GUARD WALL**

**PROPOSED ESTIMATE FOR CONSTRUCTION OF SEMI PROCESSING UNIT.**

**[ The Rate Based On P.W.D. Schedule Effect from 1st November , 2017 ]**

Sl. No	Description of item	M.F.	No.	L (m.)	B (m.)	D (m.)	Quantity (m3)	Unit	Rate (Rs.)	Amount (Rs.)
1	{ P.W.D. / Page No. 1 / Item No. 2(a)} Earth work in excavation of foundation trenches or drains, in all sorts of soil etc. (a) Depth of excavation not exceeding 1,500 mm. For Post Grouting For Guard Wall " For Step		2x10	0.850	0.850	0.750	10.838	cum.	119.27	2517.10
			1x2	22.500	0.400	0.450	8.100			
			1x2	5.300	0.400	0.450	1.908			
			2	1.500	0.575	0.150	0.259			
							21.104	cum.		
2	{ P.W.D./Page No. 2/ Item No. 4(B)} Filling in foundation or plinth by fine sand.		1	28.300	5.500	0.350	54.478	cum.	509.85	27775.35
							54.478	cum.		
3	{ P.W.D. / Page No. 47 / Item No. 3 } Supplying and laying Polythene Sheet (150gm / sq.m.) over damp proof course or below flooring or roof terracing or in foundation or in foundation trenches.		2x10	0.850	0.850		14.450	sqm.	24.00	4657.56
			1x2	22.500	0.400		18.000			
			1x2	5.300	0.400		4.240			
			2	1.500	0.575		1.725			
			1	28.300	5.500		155.650			
							194.065	sqm.		
4	{ P.W.D./Page No. 34 / Item No. 22(A)(a)} Cement Concrete with graded stone ballast 40 mm size(Excluding shuttering )etc. (A)Pakur variety (a) 1:3:6 proportion		2x10	0.850	0.850	0.100	1.445	cu.m.	5207.00	16883.05
			2	22.500	0.400	0.075	1.350			
			2	5.300	0.400	0.075	0.318			
			2	1.500	0.575	0.075	0.129			
							3.242	cu.m.		

Sl. No	Description of item	M.F.	No.	L (m.)	B (m.)	D (m.)	Quantity (m3)	Unit	Rate (Rs.)	Amount (Rs.)
5	<b>{ P. W. D./ Page No. 24 / Item No. 4(i)}</b> Ordinary Cement concrete (mix 1:2:4) with graded stone chips (20 mm nominal size) excluding shuttering and reinforcement,if any, in ground floor as per relevant IS codes. i) Pakur Variety For Post Grouting Floor		2x10	0.450	0.450	0.750	3.038	cum.	5396.74	109648.26
			1	28.800	6.000	0.100	17.280			
							20.318	cum.		
6	<b>{ P.W.D./Page No. 42/ Item No. 36 (f)}</b> Hire and labour charges for shuttering with centreing etc. (f) 25 mm to 30 mm shuttering without staging in foundation		2	28.800		0.100	5.760	sqm.	203.00	1412.88
			2	6.000		0.100	1.200			
							6.960	sqm.		
7	<b>{ P.W.D./Page No. 15 / Item No. 8(a)}</b> Brick work with 1st class bricks in cement mortar (1: 6) (a) In foundation and plinth For Guard Wall		2	22.500	0.250	0.700	7.875	cum.	5140.00	52325.20
			2	5.300	0.250	0.700	1.855			
			2	1.500	0.500	0.225	0.338			
			2	1.500	0.250	0.150	0.113			
							10.180	cum.		
8	<b>{ P.W.D./Page No. 16 / Item No. 16}</b> 125 mm. thick brick work with 1st class bricks in cement mortar (4:1) in ground floor.		20x2	0.700		0.700	19.600	sqm	705.00	22701.00
			20x2	0.450		0.700	12.600			
							32.200	sqm.		
9	<b>{ P.W.D./Page No. 189 / Item No. 1(i)(c)}</b> 15 mm thick cement sand plaster to wall(6:1) etc.		2	28.800		0.500	28.800	sqm.	136.00	4732.80
			2	6.000		0.500	6.000			
							34.800	sqm.		

Sl. No	Description of item	M.F.	No.	L (m.)	B (m.)	D (m.)	Quantity (m3)	Unit	Rate (Rs.)	Amount (Rs.)
10	{ P.W.D./Page No. 48 / Item No. 6(iii)} Artificial stone in floor, dado, staircase etc with cement concrete (1:2:4) with stone chips, laid in panels as directed with topping made with ordinary or white cement (as necessary) and marble dust in proportion (1:2) including smooth finishing and rounding off corners including raking out joints or roughening of concrete surface		1	28.800	6.000		172.800	sqm.		
							172.800	sqm.	330.00	57024.00
11	{P.W.D./Page No.192 / Item No. 15 } Neat cement punning about 1.5mm thick in wall, dado, window sill, floor etc.		2	28.800		0.500	28.800			
			2	6.000		0.500	6.000			
							34.800	sqm.	34.00	1183.20
12	{P.W.D./Page No.100 / Item No. 2(i) } M.S. structural works in roof trusses with tubular sections conforming to IS: 806-1968 & IS: 1161- 1998 cnnected to one another with bracket, gusset cleats as per design, direction of Engineer-in-charge complete including cutting to requisite size, fabrication with necessary metal arc welding conforming to IS: 816-1960 & IS- 9505 i) For trusses spanning up to 12.00 m 90 MM Dia M.S. Pipe  50 MM Dia M.S. Pipe  40 MM Dia M.S. Pipe  6 mm thick plate		1X10X3.900=39.000 M 1X10X4.300=43.000M 82.000 M X9.75 kg/m=799.50 kg							
			1X10X6.500= 65.000M   65.000 M X5.10 kg/m= 331.500 kg							
			1X7X28.750= 201.250M 201.250 M X3.61 kg/m= 726.512 kg							
			20x2x0.150x0.150= 0.900 Sqm							

Sl. No	Description of item	M.F.	No.	L (m.)	B (m.)	D (m.)	Quantity (m3)	Unit	Rate (Rs.)	Amount (Rs.)			
13	<p>{P.W.D./Page No.99 / Item No. 1(ii)}</p> <p>M.S. structural works in columns, beams etc. with simple rolled structural members (e.g. joists, angle, channel sections conforming to IS: 226, IS: 808 &amp; SP (6)- 1964 connected to one another with bracket, gussets, cleats as per design, direction of Engineer-incharge complete including cutting to requisite shape and length, fabrication with necessary bolting, metal arc welding conforming to IS: 816- 1969 &amp; IS: 1995</p> <p>II) For Structural Works in Roof Trusses etc. using joists, channels and angles of specified section weighing less than 22.5 kg/ m</p> <p>L25X25X5 MM</p>		0.900sqm X@ 47.100 kg/sqm=42.390 kg					1.899	M.T.	72951.00	138533.95		
			9X2X3.000=54.000M										
			9X4X1.600= 57.600M										
			9X2X3.000=54.000M										
			9X4X2.100=75.600M										
			2X2X6.000=24.000 M										
			2X5X6.000=60.000M										
			18X2X3.000=108.000 M										
			18X2X1.200=43.200M										
			2X2X6.000=24.000 M										
			2X4X1.200=9.600M										
			14	<p>{P.W.D./Page No.82 / Item No. 13}</p> <p>Galvanised plain sheet works (excluding supporting framework) fitted and fixed with 6 mm. dia J or L hook-bolts and nuts, sheet-bolts, limpet and bitumen washers and putty with 150 mm. end lap &amp; 50 mm minimum side lap complete. (b) In wall: with 0.63 mm. sheets.</p>		510.000 M X@ 1.80 KG/M= 918.000 KG							0.918
9	3.000					1.600	43.200	sqm.					



Sl. No	Description of item	M.F.	No.	L (m.)	B (m.)	D (m.)	Quantity (m3)	Unit	Rate (Rs.)	Amount (Rs.)
15	{P.W.D./Page No.81 / Item No. 9} Galvanised corrugated iron sheet work (excluding the supporting frame work) fitted and fixed with 10 mm. dia J or L hook-bolts, limpet and bitumen washers and putty complete with 150 mm. end lap and one corrugation minimum side lap. (Payment to be made on area of finished work)/ (i) In Roof:- b) With 0.63 mm thick sheet		9	3.000		2.000	54.000	sqm.	438.00	53085.60
			2	6.000		2.000	24.000			
							121.200			
16	{P.W.D./Page No. 221 / Item No. 8} Double knotted wove wire 1.2 m. height (11 bars), vertical 300 mm. apart, horizontal spacing starting from 88 mm. ending 200 mm. top and bottom wire 10g and all other intermediate and upright wire 9g. with finished border 2 ply twisted fencing including tightening and fixing the same to posts with staples at every bar including cost of cutting and of lapping joints in the net as necessary including cost of staples and wove wire.		1	28.800		6.500	187.200	sqm.	644.00	120556.80
							187.200	sqm.		
17	{P.W.D./Page No. 200 / Item No. 1(a)} Priming one coat on Steel or other metal surface with synthetic oil bound primer of approved quality including smoothening surfaces by sand papering etc..  90 MM dia pipe 50 MM dia pipe 40 MM dia pipe		2X9	3.000		1.200	64.800	sqm.	347.00	27482.40
			2X1	6.000		1.200	14.400			
							79.200	sqm.		
			1.00	1		82.000	0.282	23.124		
			1.00	1		65.000	0.160	10.400		
	1.00	1	201.250	0.125	25.156					
	2.20	9	3.000	1.600	95.040					
	2.20	9	3.000	2.000	118.800					
	2.20	2	6.000	2.000	52.800					
	1.00	18	3.000	1.200	64.800					

Sl. No	Description of item	M.F.	No.	L (m.)	B (m.)	D (m.)	Quantity (m3)	Unit	Rate (Rs.)	Amount (Rs.)
18	{P.W.D./Page No. 200 / Item No. 2(A)(iv)} Painting with best quality synthetic enamel paint of approved make and brand etc. (b) On Steel or other metal Surface. (iv) Two Coats (With any shade except white) Quantity same as Steel Primer	1.00	2	6.000		1.200	14.400	sqm.	29.00	11731.09
							404.520			
							404.520			
<b>TOTAL (Rs.)</b>										<b>751919.94</b>
<b>Add @ 12% for G.S.T (Rs.)</b>										<b>90230.39</b>
<b>TOTAL (Rs.)</b>										<b>842150.34</b>
<b>Add @ 1% for Cess (Rs.)</b>										<b>8421.50</b>
<b>Add @ 3% for Contingency (Rs.)</b>										<b>25264.51</b>
<b>GRAND TOTAL (Rs.)</b>										<b>875836.35</b>
<b>SAY (Rs.)</b>										<b>875800.00</b>
<b>(Rupees Eight Lakh Seventy Five Thousand Eight Hundred Only )</b>										

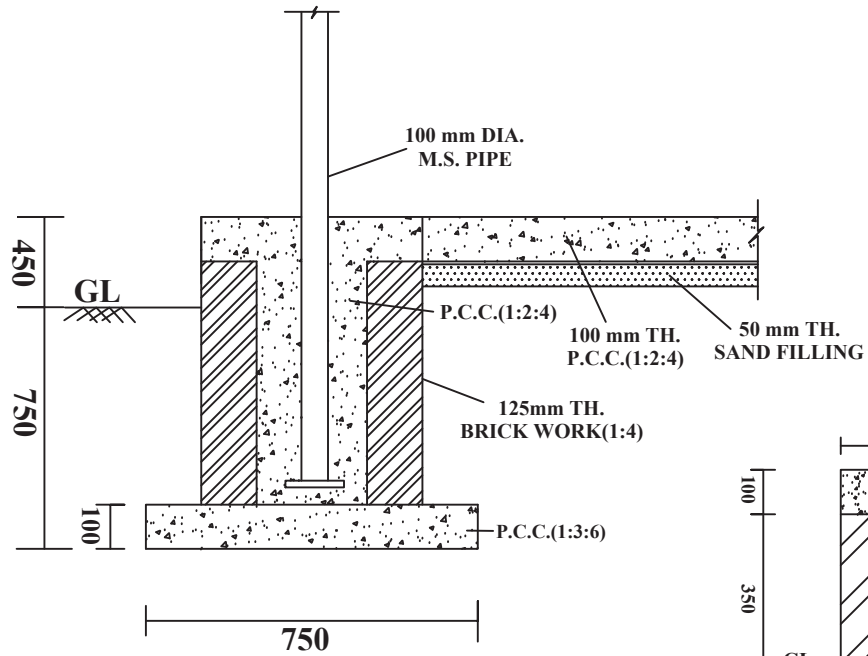
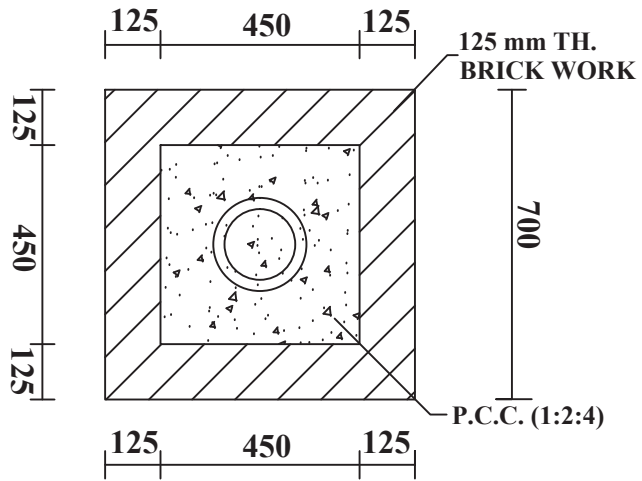

DETAILS OF POST GROUTING

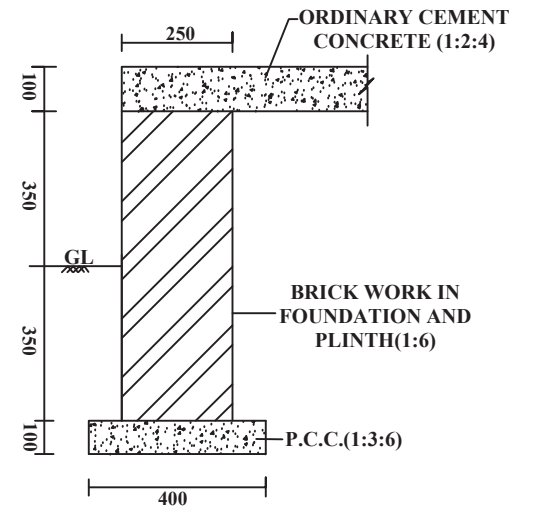

CROSS SECTION OF GUARD WALL

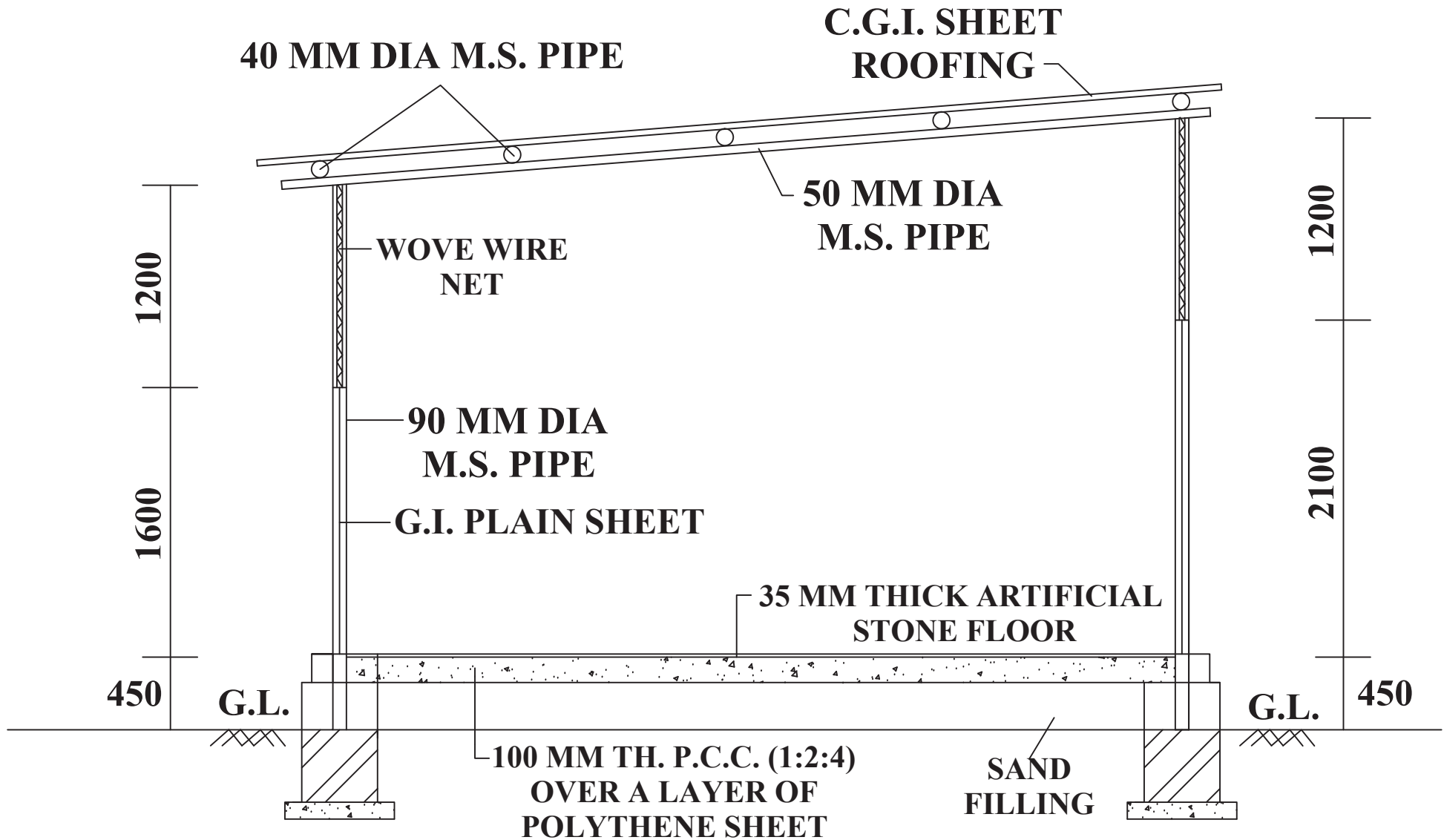

**SECTIONAL ELEVATION**

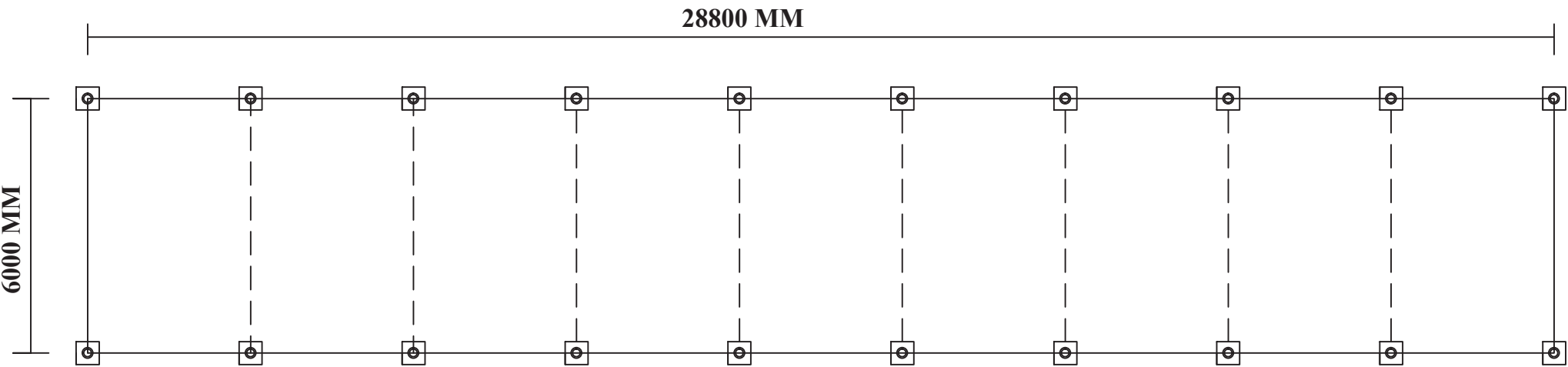

PLAN OF SEMI PROCESSING UNIT