



GOVERNMENT OF WEST BENGAL
DIRECTORATE OF FORESTS
OFFICE OF THE DIVISIONAL FOREST OFFICER,
KANGSABATI (SOUTH) DIVISION, PURULIA
Phone & Fax No.. 03252-222604, E-mail:dfoksd@gmail.com



Memo No. – 223 /2-54

Dated, Purulia, the: 19 / 02 / 2018

Notice Inviting e-Tender: - 7/WBFOR/KSD/RKVY/MS_STAND/17-18 (2nd Call)

e-Tender FOR SUPPLY OF MS STAND UNDER KANGSABATI (SOUTH) DIVISION, DIST-PURULIA, WEST BENGAL.

In pursuance to the G.O No-5400-F(Y) dt 25/6/12 and its subsequent amendment No-2254-F dt 24/4/14, Divisional Forest Officer, Howrah Division, on behalf of Governor of West Bengal, invites sealed tenders from Bonafied Co. / Contractor / Manufacturer/ firms etc. **Supply of Root Trainers/ hycopots** to Kenda Central Nursery, Manbazar-I Range, Dist: Purulia as per the schedule mentioned below:-

Schedule of Works:-

Tender no.	Name of the Work	Estimated Amount (Rs)	Location of Work	Earnest Money @2% of estimated value (Rs)	Price of Technical & Financial Bid documents & other annex only for L1 at the time of Award of Contract (AOC)	Period of Completion (Months)
7/WBFOR/KSD/RKVY/MS_STAND/17-18 (2 nd Call)	Supply of MS Iron Stand to Kenda Central Nursery, Manbazar-I Range, Dist: Purulia 300 CC MS Iron Stand- 800 Nos. & 150 CC MS Iron Stand-750 Nos.	Rs. 21,70,000/- (Twenty one lakh seventy thousand) only	Kenda Central Nursery, Manbazar-I Range, District - Purulia Under The Office Of The Divisional Forest Officer, Kangsabati South Division.	Rs. 43400/- (forty three lakh four hundred) only	1000/- (one thousand only)	One month from the date of Award of Contract

Schedule of dates

Sl. No.	Activity	Date & Time
1.	Tender Publishing date & time	19/02/2018 at 11:30 AM
2.	Document Download start date & time	20/02/2018 at 11:30 AM
3.	Bid submission start date & time	20/02/2018 at 11:30 AM
4.	Bid submission end date & time	05/03/2018 at 3:30 PM
5.	EMD physical submission end date & time	05/03/2018 at 5:00 PM
6.	Technical Bid opening date & time	08/03/2018 at 3:30 PM
7.	Date of samples check (physical)	08/03/2018
8.	Uploading of Technical Bid Evaluation sheet	After technical bid evaluation
9.	Financial Bid opening date & time	After technical bid evaluation
10.	Uploading of Financial Bid evaluation sheet	After financial bid evaluation
11.	Publishing the Name of bidder who will get the contract	After technical & financial bid evaluation

Note: 1). In case of any unscheduled holiday or on days of Bandh or natural calamity on the aforesaid dates, the next working day will be treated as scheduled / prescribed date for the same purpose.

2). The e-Tender Inviting Authority may change the venue of opening the Technical or Financial Bids in case of exigent circumstances like breakdown of communications link or conditions of force majeure.

3). The e-Tender Inviting Authority reserves the right to defer the date of opening of either Technical or Financial Proposal or both, if required.

INSTRUCTION TO BIDDERS (ITB)

Section – A

1. General Guidance for e-Tendering

1.1 Instructions / Guidelines for e-Tenderers for electronic submission of the e-Tenders online have been shown in Web site <https://wbtenders.gov.in>

1.2 Registration of Contractors

Any contractor willing to take part in the process of e-Tendering will have to be enrolled and registered with the Government e-Procurement System.

1.3 Digital Signature Certificate (DSC)

Each contractor is required to obtain a Class-II or Class-III Digital Signature Certificate (DSC) for submission of e-Tenders.

1.4 Collection of e-Tender Documents

The contractor can search and download NIT and e-Tender documents electronically from computer once he logs on to the website mentioned in Clause 1.1 using the Digital Signature Certificate. This is the only mode of collection of e-Tender documents.

1.5 Participation in more than one work

A prospective bidder shall be allowed to participate in the job either in the capacity of individual or as a partner of a firm or registered company. If found to have applied severally in a single job, all his applications will be rejected for that job.

2. Submission of e-Tenders:

2.1 General process of submission:

Tenders are to be submitted online through the website stated in Clause 1.1 in two folders, at a time for each work, one is Technical Proposal and the other is Financial Proposal, before the prescribed date and time mentioned in the list attached. Using the Digital Signature Certificate (DSC), the documents are to be uploaded, virus scanned and digitally signed. Tenderers should specially take note of all the addendum/corrigendum related to the e-Tender and upload the latest documents as part of the e-Tender.

2.2 Technical Proposal

The Technical Proposal should contain scanned copies and/or a declaration in standardized formats of the following in two covers (folders).

A. Technical File (Statutory Cover) containing

i. NOTICE INVITING E-TENDER (NIT) (to be submitted in “NIT” Folder).

ii. Section B (Form I, Form II, Form III and AFFIDAVIT – Y)

(to be submitted in “FORMS” Folder).

iii. **Earnest Money Deposit (EMD) @ 2%** of the project cost against each project as mentioned in the schedule should be deposited by Net Banking (any listed bank) through ICICI bank payment gateway. Payment in any other means cannot be accepted. As per WB Finance Department Memo No.3975- F(y) dated – 28.07.2016.

iv. **Average annual turnover** from contracting business- Scanned copy of Summary statement of average annual turnover from contracting business for a period of last three years, i.e; 2014-2015, 2015-2016, 2016-2017 or during the period since formation of the Firm, if it was set up in less than such 3 - year period. (Vide Form-2). (to be submitted in “Forms” folder)

v. Instructions to Bidders. (to be submitted in “ITB” Folder)

vi. General Terms & Conditions of Contract. (to be submitted in “GT AND CC” Folder)

vii. Technical Specification. (to be submitted in “TS ” Folder)

viii. Drawing if Any to (“DRAWING” Folder)

i) **Note: Place of submission:** The original copy of the EMD receipt towards Earnest Money Deposit should be submitted in a sealed envelope in the Office of the **Divisional Forest Officer, Kangsabati South Division, Purulia** (Mandatory for L1 Bidder only)

ii) The **L1** bidder shall submit the hard copy of the tender documents including original copy of DD towards, EMD to the tender inviting authority during collection of the acceptance letter. Failure to submit the hard copy of the DD towards EMD after collection of acceptance letter within the time period prescribed for the purpose will be treated as an attempt for creating hindrance to the tendering process for undertaking Govt. work and should be dealt accordingly including blacklisting of the candidate **as per G.O. No. 1592- F(Y) dated 20/03/2014.**

iii) **Addenda/Corrigenda, if published:** Contractors are to keep track of all the Addendum/Corrigendum issued with a particular e-Tender and upload all the above, digitally signed, along with the NIT. Tenders submitted without the Addendum/Corrigendum will be treated as invalid and liable to be rejected.

1. My Document (Non-Statutory Cover)

Sl. No.	Category Name	Sub-Category Description	Document Name	
			(For details see Clause 3 of ITB & relevant clauses of NIT)	
A.	CERTIFICATES	CERTIFICATES	1	P.T. deposit receipt Challan
			2	GST Registration Certificate
			3	I.T.R. Acknowledgement Receipt
			4	I.T. PAN Card
			5	Voter ID Card
B.	COMPANY DETAILS	COMPANY DETAILS	1	Proprietorship Firm - Trade Licence.
			2	Partnership Firm - Registered Partnership Deed, Registered Power Attorney, Trade licence.
			3	Pvt. Ltd. Company - Registration Certificate under Company's Act, MOA & AOA, Registered Power of Attorney, Trade licence.
			4	Registered Un-employed Engineers and Labour Co-operative Societies Limited.
C.	CREDENTIAL	CREDENTIAL	1	Experience Profile- List of completed Projects of similar nature.
			2	Completion Certificate from the concerned.
D.	EQUIPMENTS	PLANT&MACHINERIES (OPTIONAL)	1	Authenticated copy of invoice, challan and way bill (Machinery)
		LABORATORY (OPTIONAL)	2	Authenticated copy of invoice, challan and way bill (Laboratory)
E.	FINANCIAL (INFO)	TURN OVER	1	Authenticated copy of the Income Tax RETURNS
		PAYMENT CERTIFICATE	2	Only Payment Certificate of work issued by the Concerned Supervisor and not the TDS certificate.
F.	DECLARATION	STRUCTURE & ORGANISATION	1	Details of Structure and Organisation ITB Section B Form III.
		AFFIDAVIT	2	An affidavit made that no adverse report against the bidder.
		TECHNICAL STAFF	3	An affidavit mentioning the name of the the technical staff as described in Clause 3(l) .

2.3. Financial Proposal

i) The financial proposal should contain the Bill of Quantities (B.O.Q.) in one cover (folder). The contractor is to quote the rate in the space marked for quoting rate in the B.O.Q.

ii) Only downloaded copy of the B.O.Q. are to be uploaded quoting the rate, virus scanned & digitally signed by the contractor.

3. Eligibility Criteria

(a) All categories of intending Tenderers shall have satisfactorily completed as a prime agency during the last 3 (three) years prior to the date of issue of this Tender Notice either of the following:

(i) At least one job (supply of ms iron stand for root trainer or similar/related product) of similar nature with an estimated cost equal to or more than the estimated cost put to this notice ; or

(ii) At least two job of similar/related nature with an estimated cost of each of the works equal to at least 50% of the estimated cost put to this notice in any one year ; or

(iii) At least three job of similar/related nature with an estimated cost of each of the works equal to at least 33% of the estimated cost put to this notice in any one year,

(b) Provided that such similar/related supplies should have been implemented in Government Department, Zilla Parishad, Government undertaking / Statutory Bodies constituted under the statute of the Government. Completion Certificate indicating Estimated Amount, Value of work-done, date of completion of the work and detail communicational address along with contact number of the Client should be submitted. [Non-statutory Documents]

(c) For the purpose of this project 'similar works' would mean supply of similar type of root trainers / hycopots in any Govt. /Undertaking / reputed MNCs etc.

(d) All categories of prospective Tenderer shall have to submit valid and upto date Professional Tax receipt challan, GST registration certificate, Income Tax return Acknowledgement receipt, PAN card issued by Income Tax Department, Voter ID card and Trade licence in respect of the prospective Tenderer. In addition to the above, any contractor who has executed any type of e-Tender works in Directorate of Forests, Govt. Of West Bengal, should submit previous credentials for his past performance, completion certificate from respective employer, the completion certificate and credentials should be signed by the officer not below the rank of Divisional Forest Officer, any other certificate signed by other officials will not be entertained (Non Statutory Documents).

(e) Where an individual person holds a Certificate in his own name duly issued to him against the company or the firm of which he happens to be a director or partner, such individual person shall, while submitting any e-Tender for and on behalf of such company or firm, invariably submit a copy of registered power of attorney showing clear authorization in his favour, by the rest of the directors of such company or the partners of such firm, to submit such e-Tender. The Power of Attorney shall have to be registered in accordance with the provisions of the Registration Act, 1908. (Non-statutory Documents).

(f). Neither prospective Tenderer nor any of the constituent partners had been debarred to participate in any e-Tender by Forest Dept., P.W.D., P.W.(R)D & P.W.(C.B.)D, Housing Department, W.B. or C.P.W.D. or M.E.S or Railways; during the last 5 (five) years prior to the date of this NIT. Such debaring will be considered as disqualification towards eligibility. (A declaration in this respect has to be furnished by the prospective bidders as per prescribed format). [Non-statutory Documents]

(g).The partnership firm shall furnish the Registered Partnership Deed and the Company shall furnish the Memorandum of Association (MOA) and Article of Association (AOA.) [Non-statutory Documents]

(h).Registered Un-employed Engineers' Co-operative Societies / Labour Co- operative Societies are required to furnish the following documents : - [Non-statutory Documents]

- i) Current "No Objection Certificate" from the Assistant Registrar of Co-operative Societies.
- ii) Supporting documents showing area of operation.
- iii) Bye-laws duly approved by the Assistant Registrar of Co-operative Societies.
- iv) Name with address and signature (in original) of the present Board of Directors of the Co-operative Society
- v) Copies of Minutes of last Annual General Meeting and Audit Report of the Co-operative Society with the evidence of submission of the same to the concerned Authorities, duly attested.

(i).The prospective Tenderers or any of their constituent partner shall neither have abandoned any work nor any of their contract have been rescinded during the last 5 (five) years. Such abandonment or rescission will be considered as disqualification towards eligibility.

(j).A prospective Tenderer shall be allowed to participate in the job either in the capacity of individual or as a partner of a firm. If the prospective Tenderer is found to have applied severally in a single job, all his applications will be rejected for that job.

(k).No conditional / Incomplete e-Tender will be accepted under any circumstances.

(l). Financial proposal of any contractor will come under the purview of consideration only if all the criteria are fulfilled as mentioned below:

The prospective bidders shall have satisfactorily completed as a prime agency during the last 3 (five) years (i.e. 2016-17, 2015-16, 2014-15) from the date of issue of this notice at least one work of similar nature (i.e. Root trainer, Hycopot etc.) under the authority of State/Central Govt./ Central Govt undertaking /Statutory Bodies constituted under the stature

of the Central/ State Govt and having a magnitude of 40(forty)% of the amount put to tender. The tendered work is subdivided in to various major items as given below. Each major item (*being the summation of associated items of the BOQ*) having an weight age of 40% or more in terms of monetary value in respect to the amount put to tender, is considered to fix the physical requirements to match credential in terms of quantity executed in previous work. Contractors are to submit credential of having executed the corresponding major item thus calculated from the BOQ of the work to the required extent as specified later.

Completion Certificate(s) submitted by the tenderer should indicate the monetary value of any one or more of such major items executed in any one work within the last 5 years. Certificate issued for partly completed work will not be considered.

Monetary value of the major item/items thus submitted will be further multiplied by the following factors to take care of the inflationary effects to arrive at the net notional amount.

Year	Description	Multiplying factor to arrive at net notional amount
Current	-	1.00
1 st	1 year preceding the current financial year	1.08
2 nd	2 years preceding the current financial year	1.16
3 rd	3 years preceding the current financial year	1.26
4 th	4 years preceding the current financial year	1.36
5 th	5 years preceding the current financial year	1.47

Description of Major Items:

1. **Earth work :**

Type-A: Earth work in dry excavation in irrigation canal / drainage channels or making embankments on rivers / sea front / drainage channels or irrigation canals, by manual / mechanical means including leads, lifts and disposal / transportation.

Type-B: Earth work in wet excavation in flowing channels, by pontoon mounted excavator including leads, lifts and disposal / transportation.

Note: For wet excavation of flowing channels, credential of earthwork should specifically be of earthwork by pontoon mounted excavator. Credential of other types of earth work will not be considered.

2. **Brickwork** of all kinds.

3. **Concrete work:** RCC / PCC of all grades of concrete in hydraulic structures (i.e. structures on rivers / seafront / drainage channels or irrigation canals), including formwork and staging.

Note: In case of tender invited for building works, concrete involved in building should also be considered over and above the above referred credential.

4. **Reinforcing Steel including Structural Steel :** All kinds of steelworks including supply / fabrication, placing, installation etc.

5. **Protection work :** (on rivers / seafront / drainage channels / irrigation channels or on embankments facing these):

Type – A : Cement concrete block pitching or lining / brick block pitching / boulder pitching / dry brick pitching / loose boulder / brick dumping / sausage / aprons / filters (conventional or geo-jute or geo-synthetic) etc. including supply, carriage and laying at site.

Type – B: Bullah and bamboo related work, porcupine cages / spurs, nylon or other crates, gunny / geo-bags including supply, carriage, placing / driving in position at site.

Note: Credential for any particular type of protection work should be used for assessing eligibility for that particular type of work.

a. Bona-fide Contractors including Consortiums and Partnership firms having experience of

completion of similar type of work during the last 5 financial years for a single contract of value not less than 50% of the estimated amount put to tender.

Completion Certificate(s) submitted by the bidder should indicate the gross value of the 100% completed work only. Completion certificates should clearly contain the Name, Designation, Address and contact no of the Officer issuing the credential.

- b. The bidder or any of their constituent partners shall neither have abandoned any work nor have any of their contracts been rescinded during the last 5 years. Such abandonment or recession will be considered as disqualification towards eligibility.
- c. Tender issuing authority may relax stipulations contained in clauses above in exceptional cases, in the interest of culminating / maturing tender process at the first call, subject to satisfaction of that authority on the competency of the bidder(s) for which such relaxation has been made, upon recording reasons of such relaxation.

4. Opening of Technical Proposal

- ✓ Technical proposals will be opened by the authorized representatives electronically from the website stated in Clause 2.1, using their Digital Signature Certificate.
- ✓ Technical proposals for those tenders whose original copies of GRIPS Challan towards EMD have been received will only be opened. Proposals corresponding to which the EMD have not been received will not be opened and will stand rejected
- ✓ Intending Tenderers may remain present, at the time of opening of e-Tender, if they so desire.
- ✓ Cover (Folder) for Statutory Documents should be opened first, if found in order, Cover (Folder) for Non-statutory Documents will be opened. If there is any deficiency in the Documents, the e-Tender will summarily be rejected.
- ✓ Decrypted (transformed into readable formats) documents of the Non statutory Cover will be downloaded, and handed over to the e-Tender Evaluation Committee (constituted for evaluation of e-Tenders).

5. Uploading of summary list of technically qualified Tenderers (1st round)

Pursuant to scrutiny and decision of the e-Tender Evaluation Committee (TEC), the summary list of eligible Tenderers with the serial number of work(s) for which their Financial Proposals will be considered will be uploaded in the web portals.

While evaluation, the Committee may summon the Tenderers and seek clarification / information or additional documents or original hard copy of any of the documents already submitted and if these cannot be produced within the stipulated time frame, their proposals will be liable for rejection.

6. Final publication of summary list of technically qualified Tenderers

Date of opening of financial bid will to be intimated in the final summary list.

7. Opening and Evaluation of Financial Proposal

- i. Financial proposals of the tenderers declared technically eligible by the Tender Accepting Authority will be opened electronically from the web portal stated in Clause 2 on the prescribed date.
- ii. The encrypted copies will be decrypted and the rates will be read out to the tenderers present at that time. All tenderers who have been shortlisted from the Technical Evaluation may participate in the opening of financial proposal.
- iii. After evaluation of Financial Proposal, by the Divisional Forest Officer, Kangsabati South Division, Purulia the final summary result will be uploaded in the web site, which will contain, name of contractors and the rates quoted by them against each work.
- iv. The Tender Accepting Authority, if required, may ask any of the tenderers to submit rate analysis to justify the rate quoted by that tenderer.

8. Procedures to be followed when one / two technically qualified Tenderers participated in any e-Tender:

Financial bid of technically qualified single / two Tenderers may not be opened. Re-Tender may be invited immediately in the process of evaluation as per norms of e-Tender as per G.O. No. 925/F(Y) dated 14/02/2017.

9. Acceptance of e-Tender (Technically eligible/qualified)

Lowest valid rate should normally be accepted. However, the e-Tender Accepting Authority does not bind himself to do so and reserves the right to reject any or all the e-Tenders, for valid reasons and also reserves the right to distribute the work amongst more than one e-Tenderer at the accepted rate after formal consultation with L1 (accepted rate) bidder and taking consent of L1 bidder for smooth & quick completion of the work.

10. Penalty for suppression / distortion of facts

If any e-Tender fails to produce the original hard copies of the documents (especially completion certificates and audited balance sheets), or any other documents on demand of the E-Tender Evaluation Committee within a specified time frame or if any deviation is detected in the hard copies from the uploaded soft copies or if there is any suppression, the e-Tenderer will be suspended from participating in the e-Tenders on e-E-Tender platform for a period of 3 (Three) years. In addition, his user ID will be deactivated and Earnest Money Deposit will stand forfeited. Besides, the **W.B. FOREST DEPARTMENT** may take appropriate legal action against such defaulting e-Tenderer.

11. Brief details on the nature of work:

a)	Name of the project	:	Supply of MS Iron Stand to Kenda Central Nursery, Manbazar-I Range under Kangsabati South Division, Dist-Purulia, West Bengal.
b)	Project ID	:	
c)	Job ID	:	
d)	Nature of Work	:	Supply of MS Iron Stand
e)	Contractors eligible to submit the e-Tender	:	As stated in item 3 (j) of this ITB.

12. Submission of original copies of documents of Tender cost and Earnest Money Deposit:

a) *Mode of Payment:*

(a) Payment by NET BANKING (any listed bank) through ICICI bank payment gateway:

- On selection of net banking as the payment mode, the bidder will be directed to ICICI bank payment gateway web page (along with a string containing a unique ID) where he will select the bank through which he wants to do the transaction.
- Bidder will make the payment after entering his unique ID and Password of the bank to process the transaction.
- Bidder will receive a confirmation message regarding success or failure of the transaction.
- If the transaction is successful, the amount paid by the bidder will get credited in the respective polling account the state government/ PSU/ autonomous body/ local body/ PRIs etc. maintained with the focal point branch of ICICI bank at R. N. Mukherjee road, Kolkata for collection of EMD or Tender fees.
- If the transaction is failure, the bidder again try for payment by going back to the first step.

13. Opening of e-Tender:

- (a) The Technical Bid shall be publicly opened by the authority receiving e-Tender or by his authorized representative, as per the Date & time Schedule mentioned in NIT.
- (b) Prospective Tenderers or their authorized representatives may be present during the opening process.
- (c) Financial Bids of only those Tenderers who would qualify in the Technical Bid evaluation will be opened.
- (d) The intending Tenderers shall clearly understand that whatever may be the outcome of the present Invitation of e-Tender, no cost of e-Tendering shall be reimbursable by the Government. The **Divisional Forest Officer, Kangsabati South Division, Purulia, W.B.** reserves the right to reject any e-Tender or all Tenders without assigning any reason whatsoever and is not liable for any cost that might have incurred by any E-Tenderer at any stage of E-Tendering.
- (e) The acceptance of the e-Tender rests with the **Divisional Forest Officer, Kangsabati South Division, Purulia, W.B.** who does not bind himself to accept the lowest e-Tender and reserves to himself the authority to reject any or all the Tenders received without assigning any reason thereof.
- (f) Intending Tenderers are encouraged to inspect the site of work and get themselves thoroughly acquainted with the local condition and all factors which may affect their rates. Prior to the site visit the intending Tenderers must inform the **Divisional Forest Officer, Kangsabati South Division, Purulia, W.B.** about the time and date of the visit.

14. The selected Contractor must arrange to procure all materials required for the proper completion of the work (as per

the Technical Specifications of the e-Tender document). The Employer will not on any account be responsible for procuring the same.

15. The selected contractor shall apply to the **Divisional Forest Officer, Kangsabati South Division, Purulia** W.B. for seeking permission for utilization of land at the close proximity of the site for arranging required plant & machineries, store of materials etc. at his own cost and responsibility. All such temporary shed etc. shall have to dismantled and all debris etc. cleared from site post completion of the work or as directed by the **Divisional Forest Officer, Kangsabati South Division, Purulia**. Once an order to the effect is issued from the **Divisional Forest Officer, Kangsabati South Division, Purulia** W.B. in this regard, it shall be brought to effect by the contractor without contest.

16. Validity of Bids:

Bid shall remain valid for a period not less than 60 (**sixty**) Days after the dead line date for Financial Bid/Sealed Bid Submission. Bid validity for a shorter period shall be rejected by e-Tender Accepting Authority as non-responsive. If any Tenderer withdraws his offer before Bid validity period without giving any satisfactory explanation for such withdrawals, he may be disqualified for submitted e-Tender to this Office and Directorate of Forests, Government of West Bengal for a minimum period of 1 (one) year.

17. Verification of credentials/onsite projects:

Before issuance of the work order, the e-Tender Accepting Authority may verify the credential and other documents of the lowest Tenderer if found necessary. After verification, if it is found that such documents submitted by the lowest Tenderer is either manufactured or false in that case, work order will not be issued in favour of the Tenderer under any circumstances and legal action will be taken against him.

18. Cancellation of e-Tender :

The Divisional Forest Officer, Kangsabati South Division, Purulia, W.B. reserves the right to cancel this N.I.T. due to unavoidable circumstances and no claim in this respect will be entertained.

19. 1. Specification of MS Iron Stand:

MS Stand: One stand Can hold 100 root trainers of 300 CC capacity, Size: 33" x 33" x 2 ft (ht), Frame-1" x ¼", Patti; ½" x ¼" Middle Support ¼" x ½" ;Stand 1" x ¼",Support Angle 3" x ½"; Weight 15 to 17 kgs.

Painted with one coat of primer and two coats of Black Japan Paint by sprayer machine.

MS Stand: One stand Can hold 160 root trainers of 150 CC capacity, Size: 33" x 33" x 2' ft (ht), Frame-1" x ¼"; Patti ½" x ¼", Middle Support ¼" x ½" ,Stand 1" x ¼", Support Angle 3" x ½", Weight 16 to 18 kgs.

Painted with one coat of primer and two coats of Black Japan Paint by sprayer machine.

2. Submission of Samples:

Submission of MS Stand Samples: For this Project, the technical proposal should be supported by submission of samples conforming to the size and specifications given in Annexure-1. The technically qualified tenderers shall submit 2 samples each of 150 CC and 300 CC Root Trainer holders made of MS Iron Stand in the office of the Divisional Forest Officer, Kangsabati South Division, Raghampur Forest Complex, Purulia-723101 before opening of **financial bid**, failing which the financial bid will not be considered for evaluation and the bid will be summarily rejected. The samples will be checked physically **by the technical committee formed by the Divisional Forest Office, Kangsabati South Division with regards to the welding strength of the joint structure and the total welding should be done instead of point welding**. The tenderers are requested to be present during the physical test to be conducted at the office of the Divisional Forest Officer, Kangsabati South Division, Raghampur Forest Complex, Purulia-723101 on date and time specified in B. (Schedule of Dates)

20. Security Deposit:

The successful tenderers will be required to deposit Security Money @ 10% of the project cost through State Government e-Procurement Portal as per Finance Deptt, Audit Branch Memo No. 3975-F(Y) dated 28th July, 2016. They will also sign agreement in the prescribed Form within 7 (seven) days from the date of acceptance of the tender, failing the Earnest Money will be forfeited to the Government. Security Deposit will be released after 180 days (6 months) from the date of final payment to the successful tenderer. In case of any irregularity, or violation of the terms and conditions of the contract agreement, the Security Deposit will be forfeited in addition to any legal action as deem fit & required.

21. Technical Specification and Quality of Works:

All works are to be carried out as per plan, specification and estimate of works subject to modification made in writing by the undersigned or his authorized officer.

22. Deduction of Taxes Etc:

Deduction of all taxes including TDS, Income Tax, GST and any other extant taxes from the Contractor's Bill as applicable **on the date of payment will be made as per Govt. rules.** Labour Welfare Cess @ 1 % (one percent) of the cost of works will be deducted from every Bill of the selected agency. **The intending tenderer should quote rates inclusive of all taxes and cess etc. They are requested to quote their rates keeping in mind all statutory deductions and depositions i.e. taxes, cess etc. to be made from their bills at prevailing rates at the date of payment of bill; as well as the tenderer will be solely responsible for deposition of taxes to be made out of the received amount of the bill as per statute . Any plea or representation in this regard will not be entertained at all at any stage.**

23. Maintenance Period:

The Contractor will be liable to maintain the work at the appropriate service level to the satisfaction of **The Divisional Forest Officer, Kangsabati South Division, Purulia, W.B.** at his own cost for a period of **(6 months or end of next rainy season in the coming year, whichever is later)** Security Period/Maintenance period, as stipulated in the BOQ. If any defect/damage is found during the period as mentioned above, the Agency shall make the same good at his own cost. Failure to do so, penal action against the Agency will be imposed by the Government as deem fit. The Agency will have to quote his rate considering the above aspect. Also the Prospective Tenderers shall have to execute the work in such a manner so that appropriate service level of the work is kept during progress of work and the period of maintenance.

24. Removal of Discrepancy:

If any discrepancy arises between two similar clauses on different notification, the clause as stated in later notification will supersede former one in following sequence :-

- a. Form of Agreement
- b. e-Tender Form
- c. Technical Specifications
- d. General Terms and Conditions
- e. Relevant PWD(W.B.) Schedule of Rates
- f. Instructions to Bidders
- g. N.I.T.

25. Mobilization Advance/ Cost Over Run:

No Mobilisation Advance and Secured Advance will be allowed. Time / cost overrun and consequent cost of escalation for any materials, labour, P.O.L. etc. will not be allowed.

26. Canvassing in connection with the e-Tender is strictly prohibited.

27. Site of work and necessary drawings may be handed over to the successful Tenderer along with the work order or in a phase wise manner as deemed fit by **The Divisional Forest Officer, Kangsabati South Division, Purulia, W.B.** No claim in this regard will be entertained.

28. The successful Tenderer will have to start the work as per the work order. He has to complete different stages of work as per time frame specified in the work order. However, DCF may subsequently alter time frame.

29. The Successful Tenderer will be required to obtain valid registration certificate & labour licence from respective offices where work by them are proposed to be carried out under the Contract Labour (Regulation & Abolition) Act, 1970 and the same should be submitted to **The Divisional Forest Officer, Kangsabati South Division, Purulia, W.B.**

30. The successful Tenderer shall have to comply with the provision of (a) the Contract Labour (Regulation & Abolition) Act, 1970 and (b) the Minimum Wages Act, 1948 and the Notifications thereof or other laws relating thereto and the rules made and orders issued thereunder from time to time, failure to do so will be treated as breach of contract and **The Divisional Forest Officer, Kangsabati South Division, Purulia, W.B.** may in his discretion cancel the contract. The contractor shall also be liable for any liability arising on account of any violation by him of the provisions of the Act and Rules made there under time to time.

31. The contractor shall not be entitled for any compensation for any loss suffered by him due to delay arising out for modification of the work, due to non-delivery of the possession of site and / or modification of work

32. Prevailing safety norms has to be followed by the successful Tenderer during execution of the work so that LTI (Loss of time due to injury) is zero.

33. Guiding schedule of works should be followed as per existing norms, patterns, lying in the working division.

34. The contractor shall abide by all acts and rules, especially but not limited to the field of forests, wildlife and biodiversity.

35. A Tenderer is to quote in figures as well as in words, his rates in the following forms in his cases against the estimated value put to e-Tender.

36. In the event of a e-Tender being submitted by a firm, it must be signed by a member or members of the firm having legal authority to do so and if called for, legal documentations in support thereon must be produced for inspection and in the case of a firm carried out by one member or a joint family it must disclose that the firm is duly registered under the Indian Partnership Act.

37. The Tenderer must sign at the bottom of each page of the e-Tender documents as a proof of acceptance of terms and conditions of the e-Tender. Overwriting shall not be allowed. All corrections, alternations etc. must be duly signed.

38. It must be clearly understood that the quantities of the various items indicated in the schedule or probable items are approximate only and may be increased or decreased during actual execution. The contractor shall remain effected by alteration.

RATES ARE FIRM FOR THE PERIOD OF THE PROJECT. IN CASE ANY ABNORMAL DEVIATION IS OBSERVED DURING THE COURSE THE E-TENDER ACCEPTING AUTHORITY MAY REFER TO THE APPROPRIATE HIGHER AUTHORITY OF DIRECTORATE OF FORESTS, GOVT. OF WEST BENGAL IN DECIDING ON THE RATE REVISIONS (IF NEEDED).

**Divisional Forest Officer
Kangsabati South Division,
Purulia**

Annexure -1

Specification of MS Iron Stand:

a	MS Stand: One stand Can hold 100 root trainers of 300 CC capacity, Size: 33" x 33" x 2 ft (ht), Frame-1" x 1/4," Patti; 1/2" x 1/4" Middle Support 1/4" x 1/2 ;Stand 1" x 1/4",Support Angle 3" x 1/2"; Weight 15 to 17 kgs. Painted with one coat of primer and two coats of Black Japan Paint by sprayer machine.
b	MS Stand: One stand Can hold 160 root trainers of 150 CC capacity, Size: 33" x 33" x 2' ft (ht), Frame-1" x 1/4"; Patti 1/2" x 1/4", Middle Support 1/4" x 1/2" ,Stand 1" x 1/4", Support Angle 3" x 1/2", Weight 16 to 18 kgs. Painted with one coat of primer and two coats of Black Japan Paint by sprayer machine.

Drawing

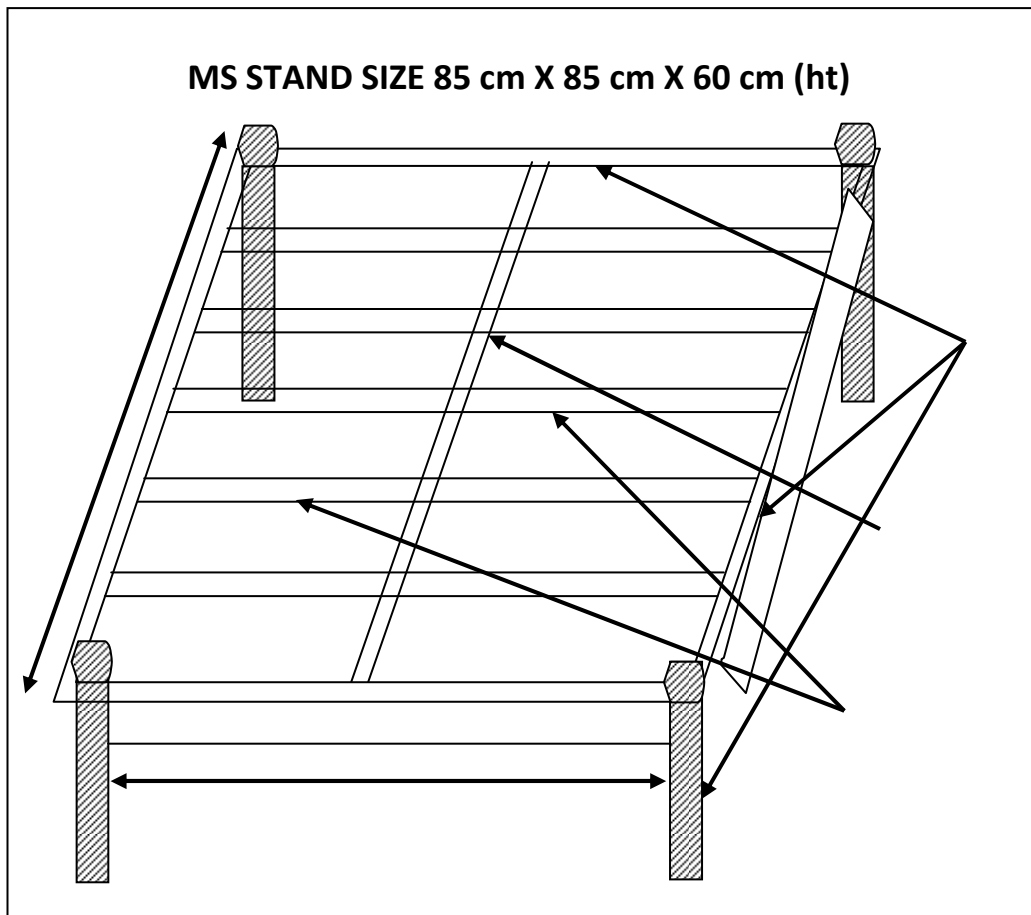

Supply of 300 CC MS Iron Stand-800 Nos. & 150 CC MS Iron Stand- 750 Nos.

**Divisional Forest Officer,
Kangsabati South Division
Purulia**

FORM NO. - 2

Certificate Regarding Summary Statement of Yearly Turnover from Contractual Business

This is to certify that the following statement is the summary of the audited Balance Sheet arrived from contractual business in favour of

.....

.....

for the three consecutive years or

for such period since inception of the Firm, if it was set in less than such three year's period.

Sl. No	Financial		Remarks
	Year	Turnover rounded up to Rs in lakh (two digit after decimal)	
1.	2013-2014		
2.	2014-2015		
3.	2015-2016		
Total			

Average Turnover: In Rs

Note:

1. Average Annual turnover is to be expressed in lakh of rupees, rounded up to two digits after decimal.
2. Average Annual turnover for 3 years is to be obtained by dividing the total turnover by 3. If the Firm was set up in less than 3 year's period, consider the total turnover for the period from inception year to the year 2014-15 and divide by the no. of years.
3. In case, the firm was set up in less than 3 year's period, mention the year of inception in the 'Remarks' column.

Signature of the Bidder with seal

ANNEXURE 1: LIST OF WORKS

Notice Inviting e-Tender : - 7/WBFOR/KSD/RKVY/MS_STAND/17-18 (2nd Call)

e-Tender Notice No.	Name of Work	Location Of Works	Price of Form *	Estimated amount put to of e-Tender (in Rs.)	Amount of EMD to be 2% deposited (in Rs.)	Period of completion of work
7/WBFOR/KSD/RKVY/MS_STAND/17-18 (2 nd Call)	Supply of Root Trainer	At Kenda Central Nursery, Beat-Kenda , Range-Manbazar-I under kangsabati South Division, Purulia	Rs.1,000.00 (One Thousand)only	21,70,000/-	43400/-	30 Days

Section – B
FORM-I
APPLICATION

To,
The Divisional Forest Officer,
Kangsabati South Division, Purulia.

Subject: Name of the Work with e-Tender reference no. _____.

Reference : (N.I.T No.)_____

Dear Sir,

Having examined the Statutory, Non-statutory and NIT documents; I/We hereby submit all the necessary information and relevant documents for evaluation.

The necessary evidence admissible by law in respect of authority assigned to us on behalf of the group of firms for application and for completion of the contract documents is attached herewith.

I/We are interested in bidding for the work mentioned above.

I/We understand that

- (a) e-Tender Inviting Authority and Accepting Authority can amend the scope and value of the contract bid under this project
- (b) e-Tender Inviting Authority and Accepting Authority reserve the right to reject any e-Tender without assigning any reason.

The application is made by me/us on behalf of _____ in the capacity of _____ duly authorized to submit the e-Tender.

Enclosure:

- (1) Technical Proposal (Envelop-1/Folder)
- (2) Financial Proposal (Envelop-2/Folder)

Date:_____

Signature of authorized officer of the firm:_____

Title & Capacity of the officer:_____

Name of the Firm with Seal:_____

Section-B
FORM II
(TO BE FILLED UP BY E-TENDERER)

To,
The Divisional Forest Officer,
Kangsabati South Division, Purulia.

Dear Sir/ Madam,

Ref:- Work for
e-Tender Reference No.

1. I/We refer to the e-Tender notice issued by you for the work ofin _____ division vide e-Tender reference no. _____ mentioned above.
2. I/ We do hereby offer to perform, provide execute, complete and maintain the works in conformity with the drawings, conditions of contract, specifications, Schedule of Quantities for the sum of Rs.....(quoted in Financial BOQ)..... only at the respective quoted ITEM WISE rates mentioned in the Schedule of Quantities.
3. I/ We have satisfied myself/ ourselves as to the site conditions, examined the drawings and all aspects of e-Tender conditions, subject above, I/ We hereby agree, should this e-Tender be accepted in whole or in part, to:
 - (a) abide by and fulfil all the terms and provisions of the said conditions annexed hereto;
 - (b) complete the works within.....days.
4. I/ We have deposited the earnest money of Rs._____ only which, I/ We note that deposited EMD, will not bear any interest and is liable for forfeiture-
 - (i) If our offer is withdrawn within the validity period of acceptance.
 - (ii) If the contract is not executed within 15 days from the date of receipt of the letter of acceptance. or
 - (iii) If the work is not commenced within 10 days after issue of work order/ handing over of the site which ever is later.
5. I/ We understand that you are not bound to accept the lowest or any e-Tender you receive.

Yours faithfully,

Signature.....
Designation :
Address :

Name of Partners of our Firm:

- 1) _____.
- 2) _____.

Section – B

**FORM – III
STRUCTURE AND ORGANISATION**

A.1. Name of the applicant (Tenderer):

A.2. Office Address:

Telephone No.:

Fax No.:

e-mail :

A.3. Name and address of Bankers:

A.4. Attach an organization chart showing the structure of the company with names of key personnel and technical staff with Bio-data

Date:_____

Signature of authorized officer of the firm:_____

Title & Capacity of the officer:_____

Name of the Firm with Seal:_____

Note: Application covers Proprietary Firm, Partnership, Pvt. Ltd. Company or Corporation

Section-B

AFFIDAVIT – Y

(To be furnished in Non-judicial stamp paper of appropriate value duly notarized)

- (I) I, the undersigned do certify that all the statements made in the attached documents are true and correct. In case of any information submitted, proved to be false or concealed, the application may be rejected and no objection/claim will be raised by the undersigned.
- (II) The undersigned also hereby certifies that neither our firm M/S_____ nor any of constituent partners had been debarred to participate in e-Tender by the Directorate of Forests, Government of West Bengal or any of the Statutory Bodies or Government Organizations in favour of whom credentials are preferred by the undersigned towards eligibility criteria claim; during the last 3 (three) years prior to the date of this N.I.T.
- (III) The undersigned would authorize and request any Bank, person, Firm, or Corporation to furnish pertinent information as deemed necessary and/or as requested by the Divisional Forest Officer, Kangsabati(South) Division, Purulia herein referred to as the e-Tender Inviting & Accepting Authority, to verify this statement.
- (IV) The undersigned understands that further qualifying information may be requested and agrees to furnish any such information at the request of the e-Tender Inviting & Accepting Authority.
- (V) Certified that I have applied in the e-Tender in the capacity of individual/as partner of a firm & I have not applied severally for the same job.

Date:_____

Signature of authorized officer of the firm:_____

Title & Capacity of the officer:_____

Name of the Firm with Seal:_____

GENERAL TERMS & CONDITIONS OF CONTRACT

1. Drawing / Map:

The work is to be carried out in accordance with drawings / maps related to these contract and specification, the priced scheduled of probable items with approximate quantities and directions or instructions which may be issued by the Tender Inviting Authority or his Representative from time to time during the execution of the contract.

2. Interpretations:

In constructing these conditions, the specifications, the schedule of quantities, e-Tender and Agreement, the following words shall have the meaning herein assigned to them except where the subject of context otherwise requires:

- I) The term Tender Inviting Authority shall mean Divisional Forest Officer Kangsabati South Division, Purulia West Bengal, and include its successor and assigns or the Officers authorized to deal with any matters which those presents are concerned on its behalf.
- II) The term REPRESENTATIVE shall mean Authorized Official of the Dy. Divisional Forest Officer, Kangsabati South Division, Purulia W.B.
- III) **CONTRACTOR** shall mean the firm or company or person whose e-Tender has been accepted by the Tender Inviting Authority and includes his (their) heirs, legal representative assigns and successors.
- IV) **SITE** shall mean the site of the contract work **including any erections thereof and any other land adjoining**
- V) **There to (inclusively as aforesaid allotted by the Tender Inviting Authority for the contractor's use).**
- VI) This **CONTRACT** shall mean Articles of Agreement, these conditions, the schedule of quantities, the general instructions to the Contractor, the specifications, the drawings / maps and correspondences by which the contract is added, amended, valued of modified in any way by mutual consent.
- (VI) **ACT OF INSOLVENCY** shall mean any act of insolvency as desired by the Presidency Towns Insolvency Act or the Provincial Insolvency Act or any amending statutes.
- (VII) **THE WORKS** shall mean the work or works to be executed or done under this contract.
- (VIII) The **SCHEDULE OF QUANTITIES, BILL OF QUANTITIES** shall mean the Schedule or Quantities as specified and forming part of contract.

3. Scope of works:

The work to be done is covered in this e-Tender. The same has been detailed in the drawings/maps and schedules of probable items with approximate quantities. It includes furnishing all materials, labour, tools, machinery and equipment and management necessary for completion of the work. All work during its progress and upon completion shall conform to lines as shown on the drawing/map furnished by the Tender Inviting Authority. Should any details essential for efficient completion of the work be omitted from the drawings/maps and specifications it shall be the responsibility of the Contractor to inform the Tender Inviting Authority and to furnish and install such details with their concurrence, so that upon completion of the proposed work the same will be acceptable and ready for use. The Tenderers are to note that the scope of work as mentioned may be reduced to any extent which is absolutely at the discretion of the Tender Inviting Authority. This reduction of the extent of work should not be a criterion for extra claim in respect of materials stored, establishment and cost incurred or any other losses occurring out of these causes. The Contractor shall carry out and complete the works in every respect in accordance with this contract and in accordance with the directions and to the satisfaction of Tender Inviting Authority who shall be the final authority. The Tender Inviting Authority may in their absolute discretion issue further area drawings/maps and /or written instructions, details, direction and explanations which are hereafter collectively referred to as the Tender Inviting Authority's instructions in regard to:

- a) The variation or modification of the design, quality or quantity of works or the addition or omission or substitution of any work.
- b) Any discrepancy in the drawings/maps or between the schedule of Quantities and /or Drawings/Maps and/or Specifications.
- c) The removal from the site of any materials brought thereon by the Contractor and the substitution of any other materials thereof.
- d) The demolition, removal and/or re-execution of any work executed by the Contractor.
- e) The dismissal from the work of any person employed thereupon.
- f) The opening up for inspection of any work covered up.

The Contractor shall forthwith comply with and duly execute any work comprised in such Tender Inviting Authority's instructions provided always that verbal instructions, directions and explanations given to the Contractor or his representative upon the works by the Tender Inviting Authority shall, if involving a variation, be confirmed in writing by the contractor within seven days. No work, for which rates are not specifically mentioned in the priced schedule of

quantities, shall be taken up without written permission of the Tender Inviting Authority. Rates of items not mentioned in the Priced Schedule of Quantities shall be fixed by the Tender Inviting Authority, as provided in Clause **VARIATION**. If complete with the Tender Inviting Authority's instructions as aforesaid involves work and/or loss beyond that contemplated by the Contract then, unless the same were issued owing to some breach of this contract by The Contractor, the Tender Inviting Authority shall pay to the Contractor the price of the said work an extra to be valued as hereinafter provided and /or loss.

4. Variations:

The Contractor may when authorized and shall when directed, in writing by the Tender Inviting Authority may for that purpose appoint, shall be bound to add or omit from or vary the works shown upon the Drawings/Maps or described in specification or included in the Schedule of Quantities but the Contractor shall make no addition, omission or variation without such authorization or direction. A verbal authority or direction by the Tender Inviting Authority, if confirmed by the Contractor in writing within seven days, be deemed to have been given in writing. No claim for an extra shall be allowed unless it shall have been executed by the Contractor on specific direction on the Tender Inviting Authority as herein mentioned any variation i.e. additions, omissions or substitutions shall vitiate the Contract.

(a)For the rates for the additional, altered or substituted work for items mentioned in the e-Tender, the e-Tender at quoted rates will be applicable.

(b) For the rates for the additional, altered or substituted work for items not mentioned in the e-Tender, the Contractor shall, within 7days of the date of receipt of the order to carry out the work, inform the Tender Inviting Authority of the rates which it is his intention to charge for such class of work, supported by required documents, vouchers etc. and analysis of rates claimed and the Tender Inviting Authority shall determine the rates on the basis of the prevalent market rates and certify for the payment accordingly. The analysis shall be prepared on the basis of actual cost of materials and labour plus 10 (ten) per-cent to cover overhead supervision and profit etc.

However, the Tender Inviting Authority, by notice in writing, will be at liberty to cancel their order to carry out such work and arrange to carry out as they may consider advisable. But under no circumstances, the Contractor shall suspend the work on the plea of non-settlement of the rates of item falling under this clause.

(c) Where extra work cannot be properly measured or valued, the Contractor shall be allowed day work price as the net rates stated in the e-Tender or the schedule of quantities, if not so stated, then in accordance with local day work rates and wages for the district provided that in either case vouchers specifying the daily time(and if required by the Tender Inviting Authority the workman's names) and materials used be delivered for verification to the Tender Inviting Authority at or before the end of the work following that in which the work has been executed.

(d) As regards determination of the rates, the decision of the Tender Inviting Authority shall be accepted as final. No supplementary items shall be taken up for execution except with prior written approval of the e Tender Inviting Authority. The Tender Inviting Authority is not bound to recognize the cost of materials furnished in vouchers and in case the market value of such materials are found to be lower than the depicted in the vouchers the Tender Inviting Authority at their discretion will fix the price of such materials based upon market value. The contractor may be asked to produce original bills and /or Cash Memos in respect of purchases of such materials from market. Bills and Cash Memos in this regards shall not be entertained unless purchases are affected from registered regular merchants engaged in the trade of such items.

5. Deviations: No deviation from the contract will on any account be allowed unless an order in writing is obtained from the Tender Inviting Authority.

6. Site Conditions:

The contractor shall inspect the work site where the work under this contract are to be carried out, and note carefully the area restrictions and obtain for themselves at their own responsibility all the information which may be necessary for the purpose of the successful execution of the contracted work. They must also make themselves conversant with all the local conditions, means of access to the site of work, transport facilities and character of the work, the supply of materials, conditions affecting labour and other matter that may affect their e-Tender. Tender Inviting Authority does not undertake any responsibility, to obtain any concessions, permission from the owner of the adjoining plot or from other party in respect of any allowance, access, encroachments etc. whether for the facility of the works or otherwise. No claim therefore will be entertained should Contractors have failed to comply with this condition. All equipment required to be maintained are to be kept free from damages due to operation connection with the work. The site shall be made available to the Contractors in the present condition. Site organization within this site boundary shall be the responsibility of the Contractors.

7. Persons E-Tendering shall visit SITE Etc.

Persons e-Tendering shall visit the site and make themselves thoroughly acquainted with the Nature and requirements of the case, facilities of transport, conditions affecting labour and materials and removal of rubbish, cost of carriage freight and other charges and shall allow for in their Tenders for any special difficulty in carrying out the work.

8. Contractor to provide everything necessary:

The Contractor shall provide everything necessary (all inclusive and fixed rates for the proper execution of the work according to the intent and meaning of the drawings/maps, schedule of probable items with approximate quantities, specifications taken together whether the same may or may not be particularly shown or described there in provided that the same can reasonably be inferred therefore and if the Contractor finds any discrepancy therein, he will immediately refer the case in writing to the Tender Inviting Authority whose decision shall be final and binding on the parties. Figures dimensions shall be followed in; preference to scale. The Tender Inviting Authority shall on no account be responsible for the expense incurred by the Contractor for hired ground or water obtained from elsewhere. The quantities given in the schedule of quantities are only indicative being based on preliminary design and are liable to modification in the final design. The schedule of items and quantities include so far as can at present be determined, every materials which the Contractor is likely to be called upon to perform or supply. The rate quoted against individual item will be inclusive of everything necessary to complete the said items of the work within the contemplation of the contract and beyond the unit prices no extra payment will be allowed for individual or contingent work, labour and /or materials inclusive of all taxes and duties whatsoever except for specific items, if any, stipulated in the e-Tender documents. The Contractor shall supply, fix and maintain at his own cost during the execution of any work necessary for alignment watching required not only for the proper execution of the said work,

9. Access:

The Tenderer /Representatives of the manufacturer of the materials (used for the work) shall at all reasonable times have free access to the work site/and or other places where materials are being prepared for the contract and also to any place the materials are lying or from who they are being obtained and the Contractor shall give every facility to the all of them and their representatives necessary for inspection and examination and test of the materials and workmanship. Except the representatives of Public Authorities no person shall be allowed on the work at any time without the written permission of the Tender Inviting Authority. If any, work is to be done at a place other then the site of the work, the Contractor shall obtain the written permission of the Tender Inviting Authority for doing so.

10. Quality of Materials & Workmanship:

All the works specified and provided for in the specification or which may be required to be done in order to perform and complete and part thereof shall be executed in the best and most workmanlike manner with materials to the best and approved quality of the respective kinds in accordance with the particulars contained in and implied by the specification and as represented by the drawings/maps or according to such other additional particulars and instructions as may from time to time be given by the Tender Inviting Authority during the execution of the work and to their entire satisfaction.

11. Contractor's Employees:

The Contractor shall keep for the full time a qualified and **skilled supervisor as defined in the ITB- A** and approved by the Employer, assisted with adequate staff constantly on the work, who will be responsible for the carrying out of the work to the true meaning of the specifications and schedule and quantities and instructions and directions given to him by the Employer. Any directions or instructions given to him in writing shall be held to have been to the Contractor officially.

The Employer/Authorized representative will have at all times access to the work site for inspection and examination of the work and materials proposed to be used. Authorised representatives of the Contractor shall have power of Attorney for receiving materials, cheque, signing measurement book etc. Any Supervisor, foreman, labour or other persons employed on the work by the contractor who

fails or refuses to perform the work in the manner specified herein shall be discharged immediately, and such persons shall not again be employed on the work. When required in writing by the Employer the Contractor shall discharge any person(s) who is, in their opinion, incompetent, disorderly or otherwise unsatisfactory. Such Discharge shall not be the basis of any claim for compensation or damages against the Employer or any of its officers or employees.

The Contractors shall keep the Employer saved, harmless and indemnified against claims if any of the workmen and all costs and expenses as may be incurred by the Employer in connection with any claim that may be made by any workman. The Contractor shall arrange to provide first aid treatment to the labourers engaged on the works. He shall within 24 hours of the occurrence of any accident at or about the site or in connection with execution of the works, report such accident to the Employer and also to the competent authority where such report is required by law.

12. Temporary Water Supply:

The Contractor shall make suitable arrangement for supply of water for the work. The Contractor shall have to make their own arrangement for carrying water at the work site.

13. Clearing Away:

All rubbish and superfluous materials either from Contractor's own work or from works of other agencies shall be removed from the work site on completion to the satisfaction of the Tender Inviting Authority.

14. Contractor Not To Sublet:

15. The Contractor shall not without the written consent and approval of the Tender Inviting Authority assign the agreement or sublet any portion of the work.

16. Agreement:

The successful Tenderer shall have to enter into an agreement with the Tender Inviting Authority. Stamp duty and all other costs connected with execution of such agreement shall be borne by the successful Tenderers.

17. Materials:

The selected Contractor must arrange to procure all materials required for the proper completion of the work. The Tender Inviting Authority will not on any account be responsible for procuring the same. The non-availability of the above materials shall not in any way be considered to be an excuse for the extension of time.

18. Method of Measurement:

Unless otherwise mentioned in the schedule of quantities the measurement will be net quantities of the work produced in accordance with the up-to-date rules laid down by the Indian Standard Institution. In the event of any disputes with regard to the measurement of work executed the decision of the Tender Inviting Authority shall be final and binding.

19. PAYMENT:

RUNNING ACCOUNT PAYMENTS:

Payment on Running Bills, at the discretion of the Tender Inviting Authority, shall be made to the Contractor on the bills certified by the Representative of the Tender Inviting Authority. All bills shall be prepared by the Contractor in the form prescribed by the Tender Inviting Authority. For this purpose, the Contractor must submit his/their R.A. Bills in the proper form duly accompanied by detailed measurements of works done and showing the deductions for previous payment received by him and also the deduction towards cost of materials(if any), supplied by the Tender Inviting Authority, the contractor shall be paid against measured bills only. Intermediate payments shall be regarded as payments by way of advance against the final payment any and not preclude the requiring of bad unsound and imperfect or unskilled work to be demolished, removed and taken away and reconstructed, or to be any part thereof in any respect or the accruing of any claim, nor shall it conclude, determine or affect in any way the powers of the Tender Inviting Authority, under these conditions or any of them so as to the final settlement and adjustment of the accounts or otherwise or in any other way vary or affect the contract. *Payment on R.A. Bill will be made after deduction of statutory deductions like, I.Tax, Labour Welfare Cess, CGST & SGST etc as per rule.* Payment on materials stocked at site shall not be made. Payment of supplementary items shall only be made after those one entered properly in the site instruction book, approved and sanctioned by the Employer.

20. Final Payment:

The final bill shall be accompanied by a certificate of completion **from the supervision Officer**. Payment of final bill shall be made within a month of submission of the same. The acceptance of payment of the final bill by the Contractor would indicate that he will have no further claim in respect of the work executed. The security money shall be refunded after 180 days from issue of completion certificate that the Contractor has rectified all defect, to the satisfaction of the Tender Inviting Authority.

21. Substitution:

Should the Contractor desire to substitute any materials and workmanship, he must obtain the approval of the Tender Inviting Authority, in writing for any such substitution well in advance. Materials designated in this specification indefinitely by such terms and 'Equal' or other Approved etc. shall be considered as coming under the provisions of this clause as substitutions and no such materials shall be used until specific approved by the Tender Inviting Authority has been obtained in writing.

22. Commencement and Completion of Work:

EXTENSION OF TIME AND LIQUIDATED DAMAGES FOR DELAY:

The entire work is to be completed in all respects in stipulated times as mentioned in the e-Tender Notice from the date of issue of work order. Time is essence of contract and shall be strictly observed by the Contractor. The date of

commencement of the work shall be the date on which the work order is issued to the Contractor or the date when the Contractor take possession of the site officially whichever is later. The Contractor shall complete the work in all respects to the satisfaction of Tender Inviting Authority within the stipulated time, failing which the contractor shall be bound to pay compensation @ 0.5% (half percent) over the total e-Tender value of work for delay of every week or part of a week by way of liquidated damages and not as penalty. Provided always that the entire amount of compensation to be paid under the provision of this clause shall not exceed 10% of the contract price. The payment of deduction of such damages shall not relieve the contractor of his obligation to complete the work or from any other obligation and liability under the contract. The contractor shall within 5 (Five) days of receipt of intimation that his e-Tender has been accepted to submit the Tender Inviting Authority an abstract programme of work so drawn as would enable him to complete the work within the time contemplated. The abstract programme must indicate the work within the time contemplated. The abstract programme must indicate dates of starting and completion of respective parts of sections of the work. The abstract programme would be subjected to the approval of the Tender Inviting Authority who will have the power of making such modification there in as found necessary. The actual progress as compared with this chart will be reviewed periodically. If the contractor be delayed in the progress of the work by exceptional weather condition, civil commotion, strike or lock-outs, fire, unusual delay in transportation of unavoidable casualties, act of public enemy, acts of the government, any acts of the authority or of another contractor in the performance of his contract with the employer or any other causes beyond the contractor's control, the contractor shall apply in writing to the Tender Inviting Authority for an extension of time of the completion of work or the part or section concerned within 10 (Ten) days of such occurrence, but before the expiry of the stipulated date of completion. The Tender Inviting Authority shall on such application make an enquiry and may grant such extension of time as they think justified. The decision of the employer in this respect shall be final and binding on the contractor. The work shall not be considered as completed until the Supervision Officer has certified in writing that they have been completed.

23. Escalation of Prices:

The rates quoted by the Contractor shall be firm throughout the tenure of the contract (including extension of time, if any granted) and will not be subject to any fluctuation due to increase in cost of materials, labour, sales tax, Octroi etc.

24. Damage to Persons and Property/Insurance in respect of:

The Contractor shall be responsible for all injury to persons/labourers or things or adjacent forest property which may arise from the operations or neglect of himself or of any sub-contractor or of any of his sub-contractor's employees, whether such injury or damage arises from carelessness, accident or any other cause whatever in any way connected with the carrying out of his contract.

The contractor shall indemnify the employer and held them harmless in respect of all and any expenses arising from any such injury or damage to persons or property as aforesaid and also in respect of any claim made in respect of injury or damage under any acts of Government or otherwise and also in respect of any award or compensation or the Contractor shall restore and repair all damage of every sort mentioned in this clause so as to deliver up to the whole of contract works complete and perfect in every respect so as to make good or otherwise satisfy all claims for damage to the property of the third parties. The contractor shall indemnify the Employer against all claims which may made against the Employer by any member of the public or other third party in respect of anything which may arise in respect of the works or in consequence thereof and shall at his own expense arrange to effect and maintain, until the completion of the contractor with any approved Insurance Company, a policy of insurance in the joint policy or policies with the Employer from time to time during the currency of this contract, and shall duly and punctually pay the premium payable thereof and if so required produce receipts for such payments, for the inspection of the Employer. The Contractor shall also indemnify the Employer against all claims which may be made upon the Employer, whether under the workman's Compensation Act or any other Stature in force during the currency of this contract or common law in respect of any injury to any of the contractor's or /and sub-contractor workmen or labour and shall at his own expense effect and maintain until the completion of the contract, with the approved Insurance Company a policy of Insurance in the joint names of the Employer and the Contractor against sub-risks and deposit such policy or policies with the Employer from time to time during the currency of this contract. The Contractor shall be responsible for anything which may be excluded from the Insurance Policies above referred to and also for all other damage to any property arising out of an incidental to the negligent or defective carrying out of this contract. The Contractor shall also indemnify the Employer in respect of any costs, charges or expenses arising out of any claims or proceeding and also in respect of any award of compensation of damages arising therefore the Employer shall be at liberty and have the power to deduct the amount of any damages, compensation costs, charges and expenses arising or to become due or to become due to the Contractor. The Contractor shall on signing the contract, issue the works and keep them insured (the works and keep them insured) until the Completion of the contract against loss or damage by the fire and /or earthquake with any approved Insurance Company in the joint name of the Employer and the Contractor for the full amount of the contract and for any further sum if called upon to be so by the Employer the premium of such further sum being allowed to the Contractor as an authorized extra. Such policy shall cover the property of the Contractor or of any sub-contractor or Employees. The Contractor shall deposit the policy and receipts for the premium with the Employer within 21 days from the date of signing the contract unless otherwise instructed by the Employer. In default of the Contractor insuring

as provide above, the Employer on his behalf may so insure and may deduct the premium paid from any money due or which may become due to the Contractor. The Contractor shall as soon as the claim under the policy is settled or the work reinstated by the Insurance Company should they elect to do so, proceed with all due diligence with the completion of the work in the same manner as through the fire had not occurred and in all respect under the same conditions of contract. The contract shall in case of rebuilding or reinstatement after fire shall be entitled to such extension of time for completion as the **Tender Inviting Authority** may deem fit.

25. Termination of Contract by Tender Inviting Authority:

If the contractor (being an individual or a firm) commit any act of insolvency or shall be adjusted as an insolvent or shall make an assignment or composition of the greater part in number or amount of his creditors or shall enter into a deed of assignment with his creditors, or (being incorporated company), shall have an order made against him or pass an affective resolution for winding up either compulsorily or subject to the supervision of the court or voluntarily, or if the official assignee of the contractor shall repudiate the contract, or if the official assignee or the liquidator in any such winding up shall be unable within 7 (Seven) days after notice to him requiring him to do so, to show to the responsible satisfaction of the employer that he is able to carry out and fulfil the contract and if required by the employer to give security or if the contractor (whether in individual form or incorporated company) shall suffer any payment under this contract to be attached by or on behalf of any of the creditors of the contractor or if the contractors shall assign or sublet the contract without the consent in writing of the employer first obtained if the contractor shall change or encumber this contract or any payment due to which may become due to the contractor their under or if the employer shall certify in writing of that in his opinion the contractor :

- a) has abandoned the contract, or
- b) has failed to commence the work, or has without any lawful excuse under these conditions suspended the progress of the work for 14 days after receiving from the Employer written notice to proceed, or
- c) has failed to proceed with the work such due diligence and failed to make such due progress as would enable the work to be completed within the time agreed upon, after receiving from Employer to employ more men, or,
- d) has failed to remove materials from site or to pull down and retained work within 7 days after receiving from the Employer as written notice that the said materials or work were condemned or rejected by the Employer under those conditions, or,
- e) has neglected or failed persistently to observe and perform all or any of the acts, matter or things by this contract to be observed and performed by the Contractor for 7 days after written notice shall have been given to the contract requiring the Contractor to observe or perform he same, or
- f) has to the detriment of good workmanship or define of the Employers instruction to the contrary sublet any part of the contract.

Then and in any of the said causes the employer notwithstanding any previous order after giving 7 (Seven) days notice in writing to the contractors, determine the contract, but without thereby affecting the powers of the employer of the obligations and liabilities of the contractor, the whole of which shall continue to be in force as fully as if the contractor has not been so determine and as if the works subsequently executed has been executed by or on behalf of the contractor and further the employer, his agents or representative may enter upon and take possession of the works and all plants, tools, shades, machinery and other power tools, utensils and materials, lying upon the premises or the adjoining land or roads and use the same as his own property or may employ the by means of his own representative and workman in carrying on and completing the work or by employing any other contractors or other persons or person to complete the work, and the contractor shall not in any way interrupt, or do any matter or thing to prevent or hinder such other contractor or other person or persons employed for completing and finishing or using the materials and plant for the work when the works shall be completed or as soon thereafter as convenient, the employer shall give a notice in writing to the contractor to remove his surplus materials and plant and should the contractor failed to do so within a period of 14 (Fourteen) days after receipt thereof by him the employer may sell the same by public auction and shall give credit to the contractor or for the amount so realised.

The employer shall thereafter ascertain and certify in writing under his hand that (if anything) shall be due or payable to or by the employer, for the value of the said plant and materials so taken possession of by the employer and the expense or loss which the employer shall have been put to in getting the work to be so completed and amount if any owing to the contractor and the amount which shall be certified shall there upon be paid by the employer as the case may be and the certificate shall there upon be paid by the employer, as the case may be and the certificate of the employer shall be final and conclusive between the parties.

26. Settlement of Dispute, Arbitration:

Except where otherwise provided in the Contract, all questions and disputes relating to the meaning of the specifications, designs, drawings and instruction herein before mentioned and as to the quality of workmanship or

materials used on the work, or as to any other question, claim, rights, matter, or things whatsoever, in any way arising out of or relating to the contract, design, drawings, specifications estimates, instructions, orders or these conditions or otherwise concerning the works or the execution or failure or execute the same, whether arising during the progress of the work or after the completion or **abandonment** thereof shall be referred to the sole arbitration of the Chief Conservator of Forests, South West Circle, Directorate of Forests, Govt. of West Bengal. Should the Chief Conservator of Forests, South West Circle, West Bengal, be for any reason unwilling or unable to act as such arbitrator, such questions and disputes shall be referred to an arbitrator to be appointed by the DIRECTORATE OF FORESTS, GOVT OF WEST BENGAL. The award of the arbitrator shall be final, conclusive and binding both parties to this contract and no suit shall lie in Civil Court in respect of the award by the Arbitrator.

Divisional Forest Officer
Kangsabati South Division, Purulia

Additional Terms & Conditions

Notwithstanding anything contained in the form in which the contract is executed the following shall constitute terms and conditions of contract and part of agreement and shall be binding on the contractor.

The Divisional Forest Officer, Kangsabati South Division, Purulia or his authorised representative will be the Officer-in-Charge in respect of the contract and all correspondences concerning rates, claims, change in specification and/or design and similar important matters will be valid only if made by the Officer-in-Charge. If any correspondence of above tender is made with Officers other than the Officer-in-charge for speedy execution of works, the same will not be valid unless copies are sent to the Officer-in-Charge and approved by him. The instruction given by the Divisional Forest Officer, Purulia Division, Purulia who have been authorized to carry out the work on behalf of the Officer-in-Charge and his authorised representative shall also be valid regarding specification, supervision, approval of materials and workmanship. In case of dispute, the decision of Officer-in-Charge shall be final and binding.

The i n t e n d i n g t e n d e r e r s are to quote rate in terms of percentage higher or lower or at par which will apply to all the rates in the Tender Schedule irrespective of whether quantities are entered in the schedule or not i.e. all the items and rates as shown in the schedule with the tendered percentage increase or decrease will be applicable to this tender.

The acceptance of the tender including the right to distribute the work between two or amongst more than two tenderers will rest with the competent authority without assigning reason thereof. The accepting authority reserves right to reject any or all tenders without assigning any reason thereof.

The Tenderer shall have to comply with the provisions of (a) Contract labour (Regulation & abolition) Rules, 1970 (b) Minimum Wages Act 1948 or the modification thereof or any other laws relating thereto as will be in force from time to time.

Divisional Forest Officer, Kangsabati (North) Division or his authorised representative shall not entertain any claim whatsoever from the contractor for payment of compensation on account of idle labour on any ground.

The Tender I n v i t i n g A u t h o r i t y shall not be held liable for any compensation due to machines becoming idle for any circumstances including untimely rains, other natural calamities, strike etc.

No Price preference will be applicable to W.B. Govt. Undertaking, as per Finance Deptt. G.O. No. 8648-F(Y), dated 12th October 2012.

Imposition of any duty / tax rules etc whatsoever of its nature (after work order / Commencement and completion of the work) is to be borne by the tenderer.

No mobilization / secured advance bill will be allowed.

VAT/Sales Tax, Cess, Toll Tax, Income Tax, Ferry Charges and other Local Taxes if any are to be paid by the contractor. No extra payment will be made for these. The rates of supply and finished work items are inclusive of these.

All working tools and plants will have to be arranged by the contractor at his own cost.

The final acceptance of the tender will be subject to the receipt of approval of higher authorities.

Final payment will be made after completion of all works in the field & checking by authorised officer. The authorised officer may check the quality of the work at any point of time before submitting the report of completion.

The undersigned reserves the right to cancel the agreement at any point of time during the execution of the work if it not done as per the specifications or any terms & conditions are violated by the Contractor.

The Security Deposit will be released to the Contractor after six (6) months from the date of final payment of the bill if no irregularity is noticed within this period. In case of any irregularity, the Security Deposit will be forfeited in addition to any legal action as deem fit & required.

The successful tenderer will not assign any or part of the work(s) to any other contractor/agency.

The undersigned reserves the right to demand from the Tenderers the classification and justification of their offer. The item wise statement of their proposed expenditure analysis with a view to construct the work mentioned in the schedule of this Tender Notice. On the item wise expenditure proposed labour cost should be specifically mentioned.

Cement concrete work should be thoroughly cured for at least 14 days (21 days for roof) and to be done as per standard practice, codes and rules. Use of vibrator is obligatory for compaction of cement concrete works.

The contractor shall have no claim for any payment before completion of work.

All works are to be carried out as per plan, specification and estimate of works subject to modification made in writing by the undersigned or his authorised officer. The technical supervisor as engaged by the contractor to check work as per plan, specification and estimate of works & work measurement to be recorded time to time by the technical supervisor in the specified WMNB duly countersigned by the concerned range officer under whose jurisdiction the check Dam construction is being executed. All materials to be used as per P.W.D. specification and should be approved by the undersigned or his authorised officer before use.

Work should be started from the 2 (Two)days from the date of issuing work order, failure of which work order would be cancelled and will be offered to the next bidder.

ACC / Ambuja / Ultratech / Lafarge Cement & TISCON /SAIL/RNRL Iron Rod strictly to be used for RCC construction work.

Photography of the work at the starting, during & after completion to be submitted to the undersigned.

The terms and condition mentioned herein shall be deemed to form a part of the agreement.

If any terms and conditions of the tender are altered the same will be notified.

The successful tenderer will have to undertake such extra work(not specified in the Tender) which he would subsequently be asked to do in writing by the undersigned, the payment for such extra work will be made as per the rate of the current PWD schedule applicable to Purulia District less the rate quoted by tender.

Divisional Forest Officer
Kangsabati South Division, Purulia

Copy forwarded for wide circulation & information to:-

1. The Principal Chief Conservator of Forests(HOFF), West Bengal
2. The Chief Conservator of Forests, South West Circle, West Bengal along with two copies of the Tender Notice with the request to return one copy duly approved.
3. The Sabhadhipati, Purulia Zilla Parishad.
4. The District Magistrate, Purulia.
5. The Superintendent of Police, Purulia.
6. The Honorary Wildlife Warden, Purulia
7. The Karmadakshya, Ban-O-Bhumi sanskar Sthayee Samity, Purulia Zilla Parishad.
8. The Treasury Officer, Purulia Treasury.
9. The Divisional Forest Officer, Purulia / Kangsabati (North) Division, Purulia, West Bengal.
10. The Divisional Forest Officer, Working Plan (South) Division- II, Purulia.
11. The Divisional Manager, Purulia Forest Development Corporation Limited.
12. The Sub-Divisional Officer, Manbazar
13. The Block Development Officer, Bandwan Block.
14. The Assist. Divisional Forest Officer, Kangsabati (South) Division.
15. All Range Officers (Territorial), Kangsabati (South) Division.
16. Notice Board, Kangsabati (South) Division.
17. The Computer Operator, Kangsabati (South) Division.

Divisional Forest Officer
Kangsabati South Division
Purulia